

DOSTEC-AC

INDEX

1.-GENERAL DESCRIPTION	4
2.-PACKING AND STORAGE	5
3.-TECHNICAL FEATURES	6
4.-OPERATION	10
4.1 Operating Modes	12
4.1.1 Manual mode	12
4.1.2 Proportional mode	12
4.1.2.1 Pulse	12
4.1.2.2 % / PPM Flowmet	13
4.1.3 Analogue mode	13
4.1.3.1 0-20mA	13
4.1.3.2 4-20mA	14
4.1.4 Batch mode	15
4.1.4.1 Select start mode	15
4.1.4.2 Select stroke frequency in % (flow)	15
4.1.4.3 Select stop mode	15
4.1.5 ModBus mode	17
4.1.5.1 Remote activation	18
4.1.5.2 Test priming function	18
4.2 Configuration	18
4.2.1 Pump Calibration	18
4.2.2 Set up	19
4.2.2.1 Dosing pump	19
4.2.2.2 Units	20
4.2.2.3 Flowmeter	20
4.2.2.4 Lock code	21
4.2.2.5 ModBus	21
4.2.3 IN / OUT	22
4.2.3.1 Pressure input	22
4.2.3.2 Pulse output	22
4.2.3.3 4-20mA output	22
4.3 Alarm	23
4.3.1 Level alarm 1	23
4.3.2 Level alarm 2	23
4.3.3 Flow failure alarm	24
4.3.4 Diaphragm leakage alarm	24
4.3.5 Overpressure alarm	25
4.4 Monitor	25
4.4.1 Real Time	25
4.4.2 Counters	26
4.4.3 Info Unit	26

5.- INSTALLATION	27
5.1 Generalities	27
5.2 Block	27
5.3 Electrical connection	28
5.4 Hydraulic connection	30
5.4.1 Installation examples	30
5.4.2 Recomendations for correct installation	31
5.5 Accessories	32
5.5.1 Diaphragm leakage detector	32
5.5.2 Flow detector	32
5.5.3 Pressure sensor	32
5.5.4 Additional ventilation 115 / 230V	33
6.- START UP AND REGULATION	33
7.- MAINTENANCE	34
Parts list AC3 piston	34
Parts list AC3 diaphragm	38
Parts list AC1/2 piston	42
Parts list AC1/2 diaphragm	46
Periodical maintenance	51
Problems: causes and solutions	52
Elecrical wiring	53
CE APPROVAL DECLARATION	54
WARRANTY	54



SAFETY RULES

To avoid personal or enviromental damages and to guarantee a proper operation of the equipment, the staff in charge of the installation, set up and maintenance of the equipment must follow the instructions of this manual, specially those recommendations and warnings explicitly detailed. In addition, specific instructions for the chemical products to be dosed should be followed.



1.- GENERAL DESCRIPTION

Dostec AC is a diaphragm or piston dosing pump with advanced control for an accurate and efficient automatic dosing.

This series allows many dosing possibilities depending on the chosen head. The flow range covers from 3 to 1200 l/h (317 gph) up to pressures of 20 bar (290 psi). The correct selection of head's materials, PP, PVDF or S.S., makes this pump suitable for the most chemicals products used in water treatment, chemical industry, food and beverage and agriculture.

Operation modes

Manual: manual flow adjustment through the keyboard

Analogue: dosing flow proportional to a 0/4-20mA signal

Proportional to flow: proportional dosing to a water flow

Proportional to pulses: stroke frequency proportional to input pulses

Batch control, by volume: Dosing a defined volume, after a manual, remote or time pre-set start.

Batch control, by time: Dosing for a defined time, after a manual, remote or time pre-set start.

ModBUS: dosing control through ModBus RTU protocol

It is made up as follows:

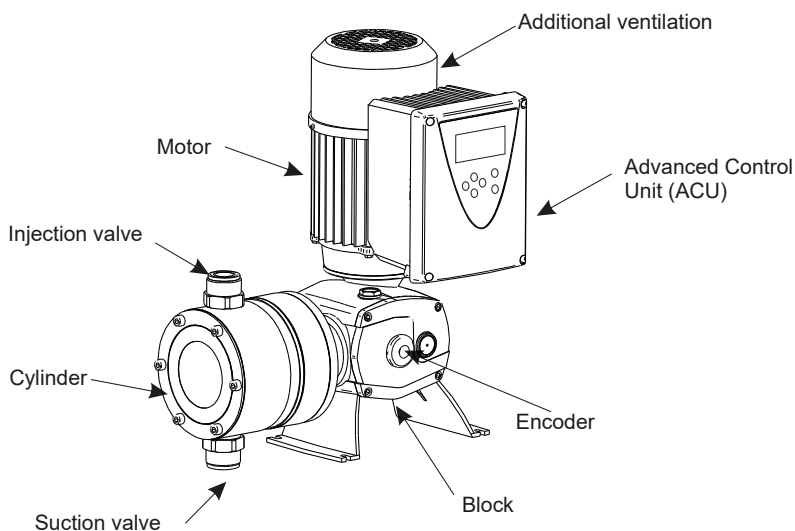



Code formulation

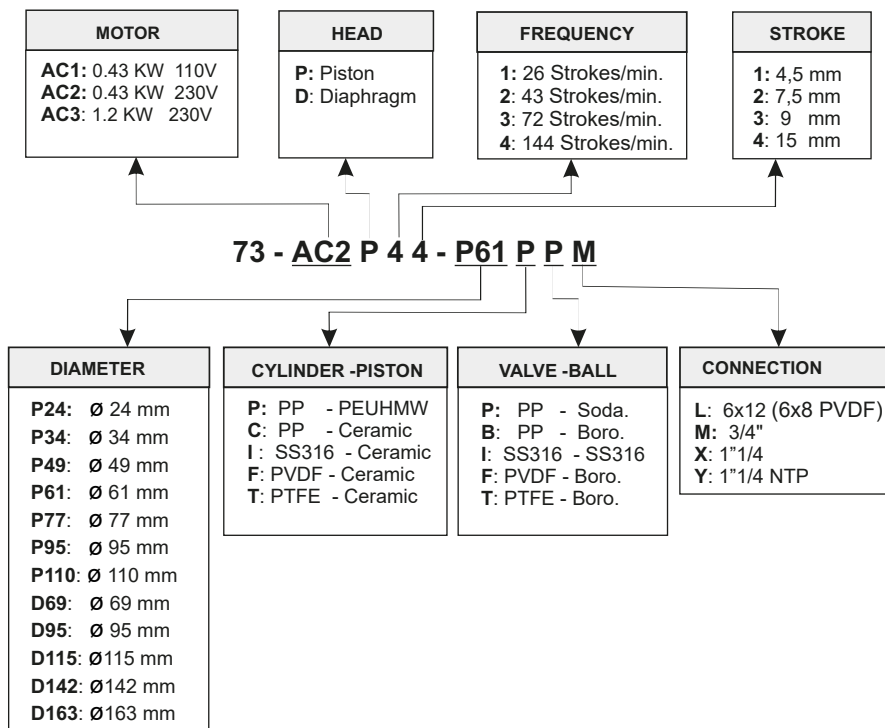

2.- PACKING AND STORAGE

The original packing is prepared so that carriage and storing of the product do not cause any damage to the product, as long as this is done far from heat sources and in dry, ventilated spaces.

The packing contains:

- DOSTEC-AC dosing pump
- Handbook
- Oil: AC1/2 250 m³
- AC3 700 m³



3.- TECHNICAL FEATURES

	CODE		FLOW		PRESSURE		* *Suction lift	
	230V	110V	l/h	GPH	bar	PSI	m	ft
Pistón	73-AC3P44-P110_X	-	1200	317	5.5	80	5	16
	73-AC3P44-P95_X	-	900	238	7.5	109	8	26
	73-AC3P44-P77_X	-	600	159	11	160	9	30
	73-AC3P34-P110_X	-	600	159	5.5	80	5	16
	73-AC2P44-P77_M	73-AC1P44-P77_M	600	159	4.5	65	1.5	5
	73-AC3P34-P95_X	-	450	119	7.5	109	8	26
	73-AC3P43-P77_X	-	400	106	12	174	9	30
	73-AC2P44-P61_M	73-AC1P44-P61_M	360	95.1	7	102	5	16
	73-AC3P34-P77_X	-	300	79.3	11	160	9	30
	73-AC2P34-P77_M	73-AC1P34-P77_M	300	79.3	4.5	65	1.5	5
	73-AC2P44-P49_M	73-AC1P44-P49_M	240	63.4	11	160	8	26
	73-AC2P34-P61_M	73-AC1P34-P61_M	180	47.6	7	102	5	16
	73-AC2P34-P49_M	73-AC1P34-P49_M	120	31.7	11	160	8	26
	73-AC2P44-P34_M	73-AC1P44-P34_M	120	31.7	15	217	9	30
	73-AC2P44-P24_M	73-AC1P44-P24_M	60	15.9	15	217	9	30
	73-AC2P34-P34_M	73-AC1P34-P34_L	60	15.9	15	217	9	30
	73-AC2P34-P24_L	73-AC1P34-P24_L	30	7.9	20/15	217	9	30
73-AC2P33-P24_L	73-AC1P33-P24_L	18	4.7	20/15	217	9	30	
73-AC2P14-P24_L	73-AC1P14-P24_L	10.5	2.7	20/15	217	9	30	
73-AC2P13-P24_L	73-AC1P13-P24_L	6	1.6	20/15	217	9	30	
73-AC2P11-P24_L	73-AC1P11-P24_L	3	0.8	20/15	217	9	30	
Diaphragm	73-AC3D44-D163_X	-	1044-1254	276-331	5	73	4	13
	73-AC3D43-D163_X	-	624-822	165-217	7	102	7	23
	73-AC3D34-D163_X	-	522-627	138-166	5	73	4	13
	73-AC3D43-D142_X	-	498-642	132-170	10	145	8	26
	73-AC3D42-D142_X	-	373-481	99-127	10	145	9	30
	73-AC2D43-D115_M	73-AC1D43-D115_M	301-342	79-90	5	72	7	23
	73-AC2D42-D115_M	73-AC1D42-D115_M	251-284	66-75	5	72	8	26
	73-AC3D33-D142_X	-	249-321	66-85	10	145	9	30
	73-AC2D43-D95_M	73-AC1D43-D95_M	173-209	45.6-55	8	116	8	26
	73-AC2D33-D115_M	73-AC1D33-D115_M	150-171	39.6-45	5	72	7	23
	73-AC2D42-D95_M	73-AC1D42-D95_M	144-173	38-45.6	8	116	9	30
	73-AC2D33-D95_M	73-AC1D33-D95_M	86-104	23-27.5	8	116	8	26
	73-AC2D43-D69_M	73-AC1D43-D69_M	83-111	22-29.4	10	145	4	13
	73-AC2D42-D69_M	73-AC1D42-D69_M	68-92	18-24.6	10	145	8	26
	73-AC2D33-D69_L	73-AC1D33-D69_L	41-55	11-14.7	10	145	4	13
	73-AC2D41-D69_L	73-AC1D41-D69_L	38-53	9.6-14	15	217	9	30
	73-AC2D31-D69_L	73-AC1D31-D69_L	19-26	5-7	15	217	9	30
73-AC2D21-D69_L	73-AC1D21-D69_L	11.5-15.5	3-4	15	217	9	30	
73-AC2D11-D69_L	73-AC1D11-D69_L	6.5-9.5	1.7-2.5	15	217	9	30	

20bars models only with ceramic piston

Models with _L include priming valve

** Suction lift when dosing head an suction pipe are full. Tested with water at 20°C



ELECTRIC CURRENT: As specified in the motor plate

POWER: 0.43 KW (0.58 Hp)
1.2 KW (1.6 Hp)

PROTECTION : IP-55

MATERIALS: Piston PEUHMW / Ceramic / SS316
Diaphragm P.T.F.E, Elastomer base reinforced with fiber
Retention FPM
Cylinder P.P. / PVDF / SS 316
Valve (body) P.P/ PVDF/ SS 316
Valve (ball) Soda lime / Borosilicate / SS316

AMBIENT TEMPERATURE: 0 ... 45 °C

MEDIA TEMPERATURE: PP: 0 ... 50 °C
PVDF: -10 ... 50 °C
SS: -10 ... 60 °C

RELATIVE HUMIDITY MAX.: 95% (without Condensation)

NOISE LEVEL dB(A): minor than 70

WEIGH: AC3: 24 Kg (53 lb)
AC2 /1: 13 Kg (29 lb)

DIMENSIONS

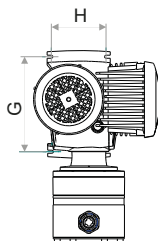
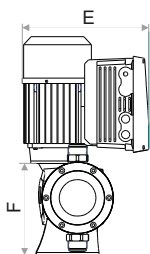
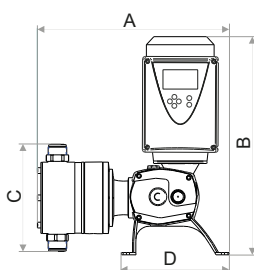

Optional assembly

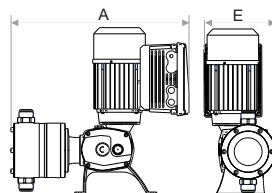

Piston	A	B	C	D	E	F	G	H	mm in
	AC3	429 16.8	490 19.3	230 9	241 9.5	285 11.2	210 8.2	212 8.3	
AC2 /1	306 12	400 15.7	154 6	180 7	270 10.6	150 5,9	155 6.1	90 3,5	

	A	E	mm in
	AC3	525 9.9	
AC2 /1	422 16.6	155 6.1	

Diaphragm	A	B	C	D	E	F	G	H	mm in	
	D163	395 15.5	490 19.3	270 10.6	241 9.5	285 11.2	210 8.2	212 8.3		122 4.8
	D142	394 15.5	490 19.3	250 9.8	241 9.5	285 11.2	210 8.2	212 8.3		122 4.8
	D115	270 10.6	400 15.7	204 8	180 7	270 10.6	150 5,9	155 6.1		90 3,5
	D95	270 10.6	400 15.7	184 7.2	180 7	270 10.6	150 5,9	155 6.1		90 3,5
	D69	274 10.6	400 15.7	154 6	180 7	270 10.6	150 5,9	155 6.1		90 3,5

	A	E	mm in	
	D163	490 19.3		225 8.8
	D142	489 19.2		215 8.4
	D115	386 15.1		180 7.1
	D95	386 15.1		170 6.7
	D69	390 15.3		155 6.1



FLOW-PRESSURE GRAPHICS

DIAPHRAGM PUMP AC1-AC2

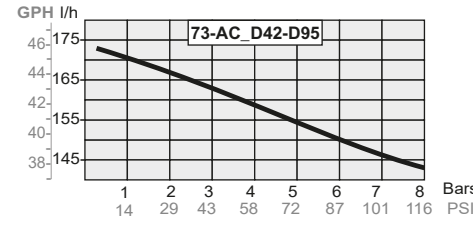
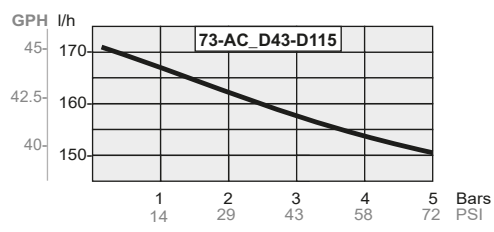
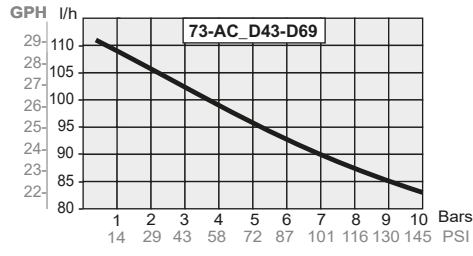
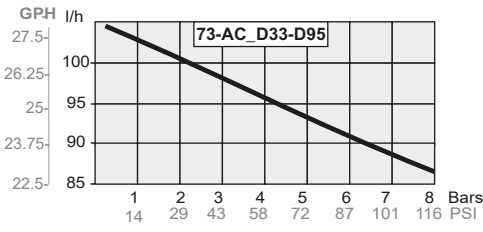
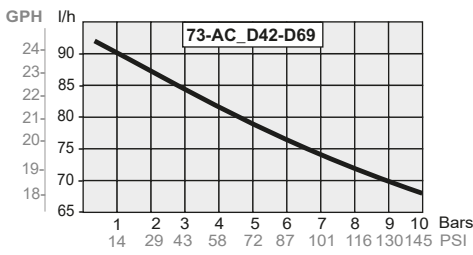
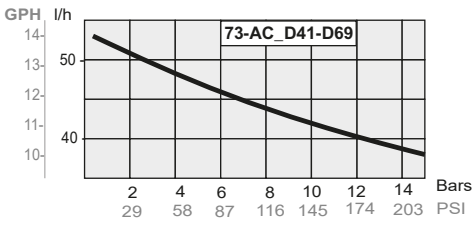
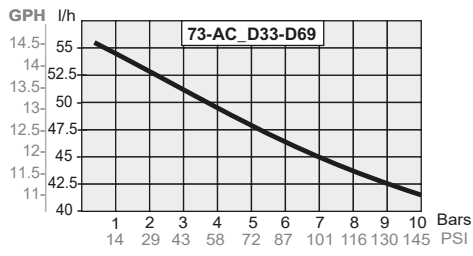
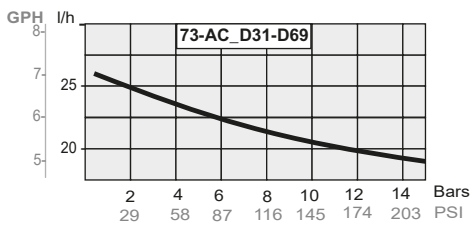
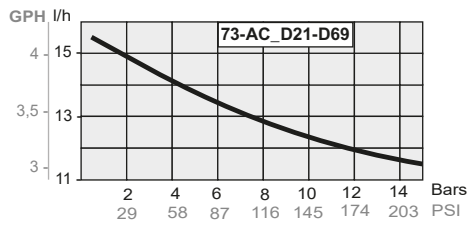
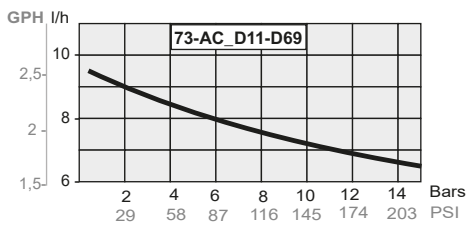

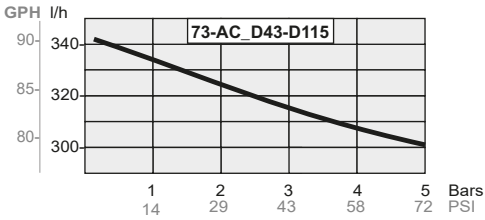
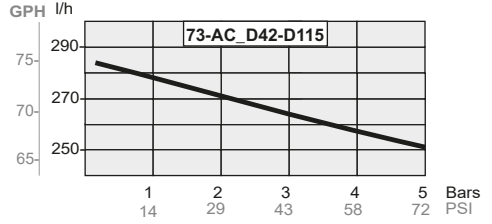
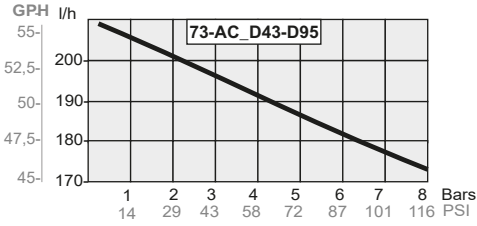

DIAPHRAGM PUMP AC3

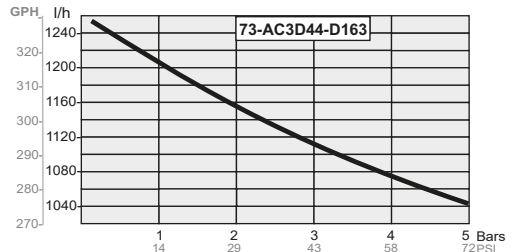
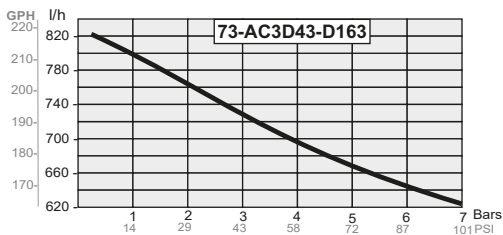
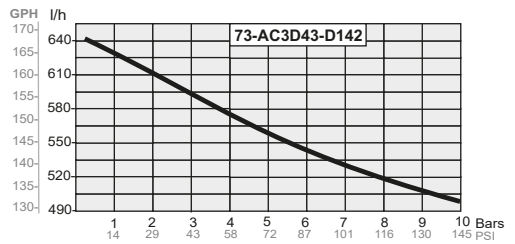
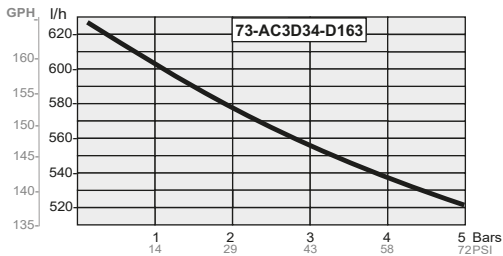
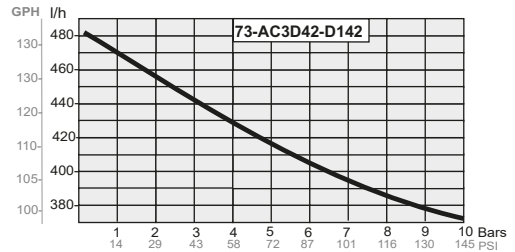
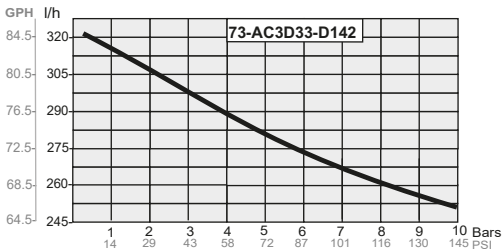



Inputs and outputs

- Analogue input 0/4-20mA
- External pulse input
- Remote on/off input
- Level sensor input (pre-empty)
- Level sensor input (empty)
- Leakage detector input
- Flow detector input
- Pressure sensor input
- Serial port RS-485 ModBus
- 4-20mA output for register and monitoring
- Pulse output for register, monitoring and 2nd pump control
- Alarm output (relay)
- Level alarm output (relay)

4.- OPERATION

The rotational motion of the motor is transmitted by the gear box, that consists of two major components, the pinion (A) and the ring gear (B). The pinion and the ring gear are linked to an axis with an eccentric bearing (C) that pushes the shaft (D) which is throated to the diaphragm or the piston (E). The return movement is made by the spring (F).





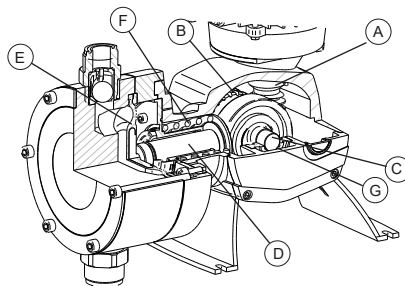

A high resolution encoder (G) checks the instantaneous position and speed and allows the Advanced Control Unit to do a close loop adjustment for torque and rotation speed.

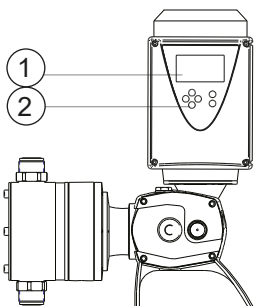
By changing the motor speed and according to the operation mode selected in the Advanced Control Unit, the dosing pump adjusts the flow to the required value within the range from 10 to 100% of the rated flow.



SYSTEM DESCRIPTION



- ① LCD Screen
- ② Keyboard:  Confirm
-  Exit without confirm
-   Increase / reduce value
-   Move left / right

LCD SCREEN DESCRIPTION

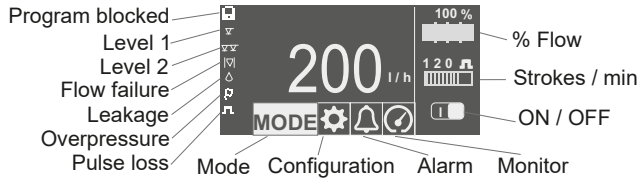

4.1 Operation Mode menu

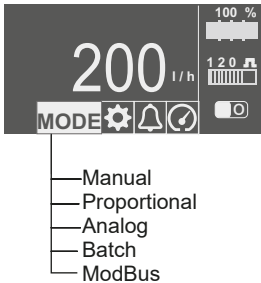

4.2 Configuration menu

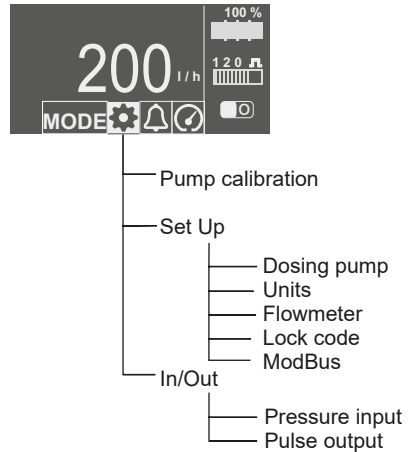

4.3 Alarm menu

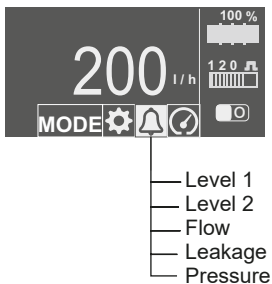

4.4 Monitor menu

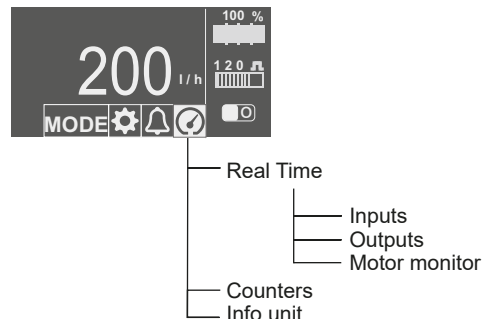



4.1 OPERATING MODES

4.1.1 Manual mode

This operation mode allows a manual regulation of dosing flow

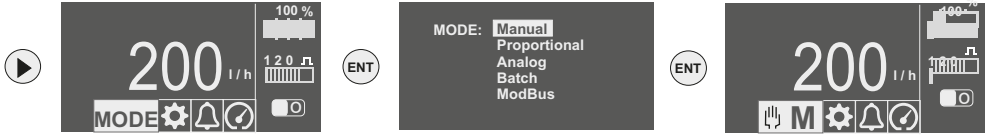

▲ ▼ Increases / reduces the flow

ENT Start / stop the pump

The pump starts only if the Remote Activation input is activated



4.1.2 Proportional mode

This operation mode allows a proportional dosing from a pulse input. Use X:Y mode to set relation between pulse input (X) and strokes of the pump (Y). Use the %/ ppm mode for a proportional dosing with a high frequency flowmeter, by introducing the proportionality in % or in ppm (parts per million)

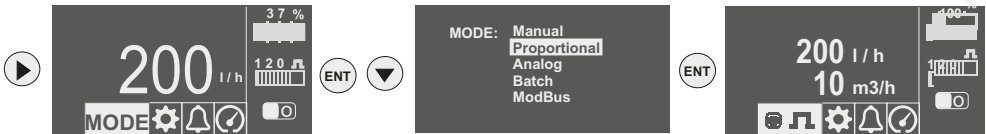

Proportional

X:Y Pulse
%/ PPM Flowmet.

- Proportional to input pulses from a flowmeter
1. X:Y for low frequency pulses
 2. %/ppm for high frequency flowmeters

Proportional mode Settings

4.1.2.1 X:Y Pulse

1. The pump turns Y strokes after receiving X pulses.
The stroke frequency can be set manually.

PROPRTIONAL X : Y

Q : M

0001 : 0001

Q = 025 %
M = 005 pulses

Select the number of input pulses

Change values with ▲ ▼ and confirm with ENT

PROPRTIONAL X : Y

Q : M

0001 : 0001

Q = 025 %
M = 005 pulses

Select the number of pump strokes

Change values with ▲ ▼ and confirm with ENT

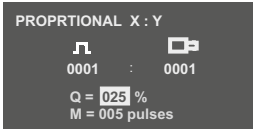

Select the pump speed in %
 Change values with and confirm with

For X:1 configuration Q must be lower than 50%

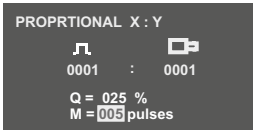

Select the maximum number of pulses in memory
 Change values with and confirm with

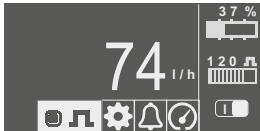

Start / stop the pump
 The pump starts only if the Remote Activation input is activated

4.1.2.2 % / PPM Flowmet.

Introduce the proportionality set point (%/ppm) and the pump will adjust the stroke frequency according to the flow reading

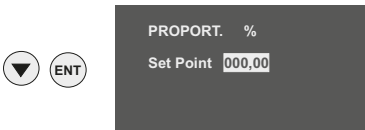

Value of proportionality in % or PPM
 Change values with and confirm with

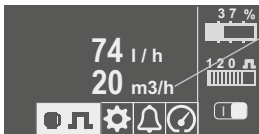

Instant water flow value
 Press ENT to start / stop the pump. The pump starts only if the Remote Activation input is activated

- * To configure the units (% / ppm) view Configuration / Units section
- * To configure the flowmeter view Configuration / Setup section

4.1.3. Analogue mode

This operation mode controls the stroke frequency according to an analogue input 0/4-20mA

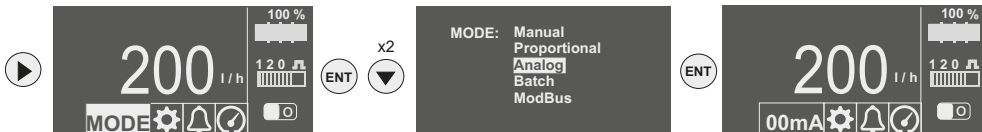

Analogue mode Settings

4.1.3.1 0-20mA

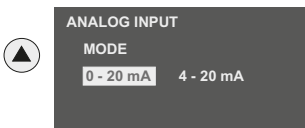

Select 0-20mA signal, and confirm with

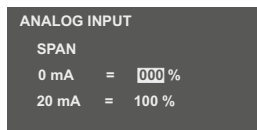

Select the flow in % for 0mA signal
Change values with and confirm with

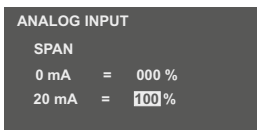

Select the flow in % for 20mA signal
Change values with and confirm with



Start / stop the pump
The pump starts only if the Remote Activation input is activated

4.1.3.2 4-20mA

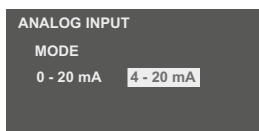

Select 4-20mA signal, and confirm with

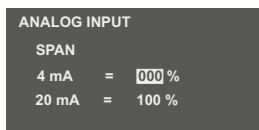

Select the flow in % for 4mA signal
Change values with and confirm with

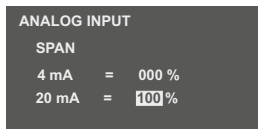

Select the flow in % for 20mA signal
Change values with and confirm with



Start / stop the pump
The pump starts only if the Remote Activation input is activated



4.1.4. Batch mode

In this operation mode it is possible to start the pump for a defined number of strokes or for a defined time. The start signal can be set manually, externally or by means of a timer. The stroke frequency can be set manually in all these operation modes

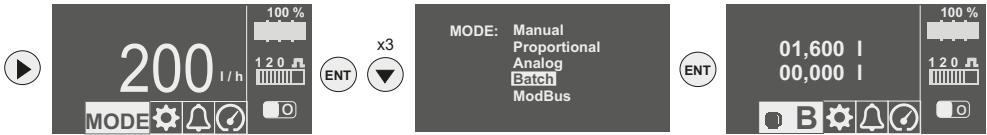

Batch mode settings

4.1.4.1 Select start mode

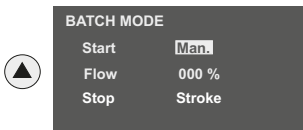

Manual: press **ENT** to start the pump

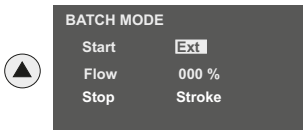

Ext.: start the pump through remote input

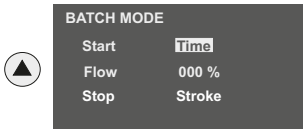

Time: start the pump through a timer by introducing a frequency (00:00:01 - 23:59:59)

4.1.4.2 Select stroke frequency in % (flow)

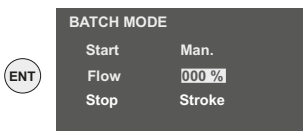

Change values with **▲** **▼** and confirm with **ENT**

4.1.4.3 Select Stop mode

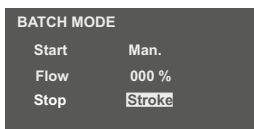

Stroke: set the number of strokes before stop

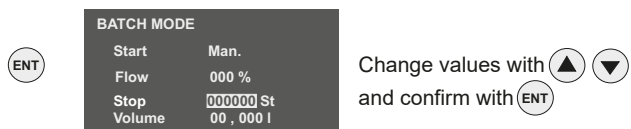

Change values with **▲** **▼** and confirm with **ENT**



BATCH MODE

Start	Man.
Flow	000 %
Stop	<u>Time</u>

Time: set the runtime before stop



BATCH MODE

Start	Man.
Flow	000 %
Stop	00 : 00 : 00
Volume	00,000 l

Change values with and confirm with

Configuration modes view

Start : Man. / Ext
Stop : Strokes

100 %
02,538 l
00,000 l
120 µl

Volume to dose

Volume counter

Start : Man. / Ext
Stop : Time

100 %
00 : 05 : 00
00 : 00 : 00
120 µl

Dosing time

Time counter

Start : Time
Stop : Strokes

100 %
00 : 10 : 00
02,538 l
00,000 l
120 µl

Start time frequency

Volume to dose

Volume counter

Start : Man. / Ext
Stop : Time

100 %
00 : 10 : 00
00 : 05 : 00
00 : 00 : 00
120 µl

Start time frequency

Dosing time

Time counter



4.1.5 ModBus mode

This operation mode allows the control of the pump through the serial port RS485 and Modbus RTU protocol

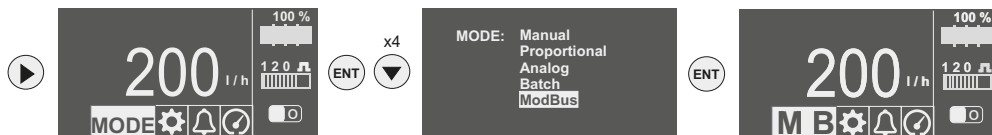

- Bus: Rs485
- Communication thorough (half-duplex) A(+), B(-), and GND
- Baud rate: 9600
- Data bits: 8
- Parity: None
- Stop bits: 1
- Hardware handshaking: No
- Character Time out: 20 mSeg.
- Message Time out: 100 mSeg

Important: if it is necessary to use a RS232/RS485 or other converters, make sure this converter doesn't produce an echo signal.

Command	Adress	Name	Value	
Read	04	00 00	Dosing Flow	Integer
Read	04	00 01	ON/OFF state	0/1
Read	04	00 02	Motor alarms:	5 Bits
		Shortcircuit	0/1	---x xxxX
		Current	0/1	---x xxXx
		Temperature	0/1	---x xXxx
		Voltage	0/1	---x Xxxx
		Encoder	0/1	---X xxxx
Read	04	00 03	Last motor alarm:	5 Bits
Read	04	00 04	Pump alarms:	5 Bits
		Level 1	0/1	---x xxxX
		Level 2	0/1	---x xxXx
		Flow	0/1	---x xXxx
		Leakage	0/1	---x Xxxx
		Pressure	0/1	---X xxxx
Read	04	00 05	Last pump alarm:	5 Bits
Write	06	00 00	Dosing flow set point	Integer
Write	06	00 01	Start / Stop	0/1

Example of reading ON/OFF state:

BYTE							
0	1	2	3	4	5	6	7
01	04	00	01	00	01	60	0A



4.1.5.1 Remote activation

An external remote control can be used to start and stop the pump by means of dry contact in pins 17-18.

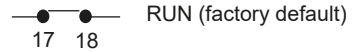
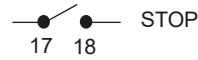
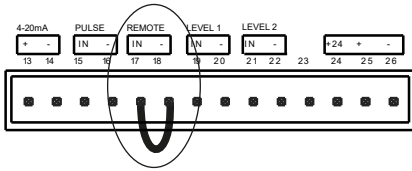

When the contact is closed (RUN) it is possible to operate the pump manually through the ENT key. After stopping the pump manually through the keyboard, it is necessary to reset the Remote Input (open and close) to start again the pump through remotely.

4.1.5.2 Test priming function

Pressing ◀ for 3 seconds in Manual mode, to start pump at maximum speed. The pump keeps running only when the ◀ is pressed.

This function allows a quick test of the unit and it becomes an assistance for priming the pump.

4.2 CONFIGURATION

4.2.1 Pump Calibration

Pump Calibration allows a flow calibration under the working conditions by doing a suction test for an specified time (TEST TIME). Introduce the Test time longer than 60 seconds to perform a properly calibration. The pump starts automatically at maximum flow for the specified time. Measure suctioned volume once the pump stops, and introduce this value in the unit. This value allows the unit to re-calibrate the dosing flow.

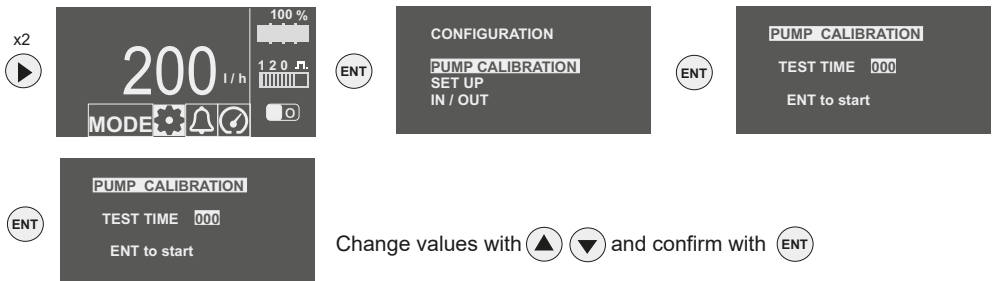



PUMP CALIBRATION

PROGRESS

Strokes 080
Speed P. 031
Max.Curr. 001

PUMP CALIBRATION

VOLUME 12.000 l

Introduce the value in the unit
and confirm with

PUMP CALIBRATION

Volume 12,000 l
Flow 1105 l/h
Vol / St. 0,127 l
Reduct. 12

Press to finish the calibration process

4.2.2 Set up

4.2.2.1 Dosing pump

Technical features of the dosing pump

x2

200 l/h

100 %

12.0

MODE

CONFIGURATION

PUMP CALIBRATION
SET UP
IN / OUT

SET UP

DOSING PUMP
UNITS
FLOWMETER
LOCK CODE
MODBUS

Rated flow

This is the flow due to the calibration test. Default value is the factory rated flow corresponding to brochure and data sheet.

DOSING PUMP

Flow 1200 l/h
Limit 100 %
Press 5.5 Bar
Regul 100 %

Change values with and confirm with

Flow limit (%)

This is the maximum flow for the pump. This parameter allows the user to limit the maximum flow of the pump.

DOSING PUMP

Flow 1200 l/h
Limit 100 %
Press 5.5 Bar
Regul 100 %

Change values with and confirm with

Maximum pressure

Maximum pressure for this unit

DOSING PUMP

Flow 1200 l/h
Limit 100 %
Press 5.5 Bar
Regul 100 %

Change values with and confirm with

Regulation

In case of stroke length regulation system available in this unit, and the regulator knob in a position different from 100%, this parameter must coincide with the regulation of the pump's knob.

DOSING PUMP

Flow 1200 l/h
Limit 100 %
Press 5.5 Bar
Regul 100 %

Change values with and confirm with



4.2.2.2 Units

Select the units for flow, pressure and proportion

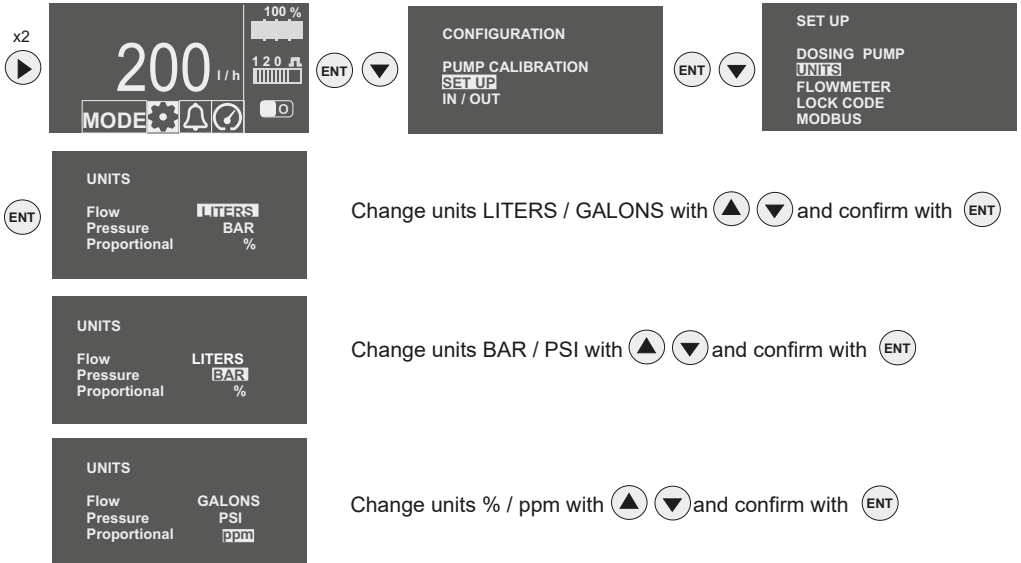

4.2.2.3 Flowmeter

Introduce the constant of the flowmeter (volume/pulse or pulses/volume) for a correct reading of water flow. Select previously the type of flowmeter, low or high the frequency output

Low frequency: watermeters with low frequency output. Constant corresponds to volume/pulse (liters/puls ; gallons/pulse)

High frequency: flowmeters with high frequency outputs. Constant K-factor corresponds to pulses/volume (pulses/litre ; pulses/galon)

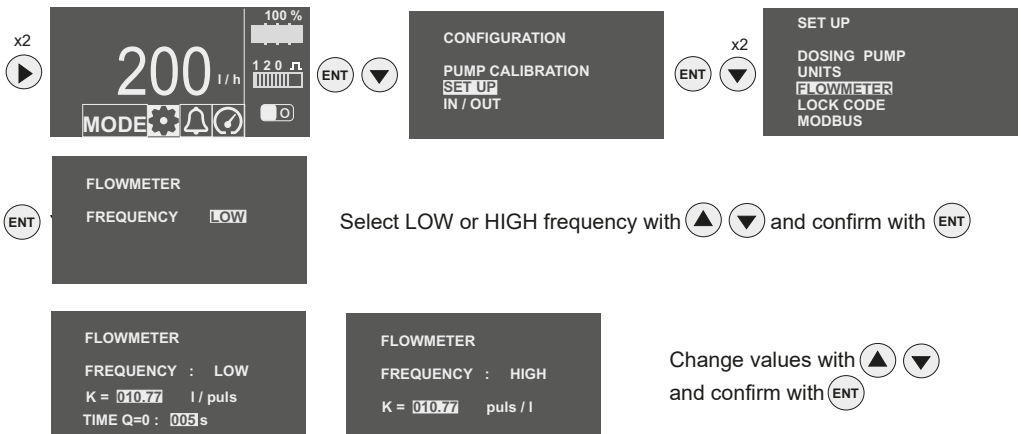

TIME Q=0, Time without receiving pulses necessary to identify as flow zero.



4.2.2.4 Lock code

Lock code to prevent changes in the units settings. When lock code is 0000 (factory default) the equipment is unlock

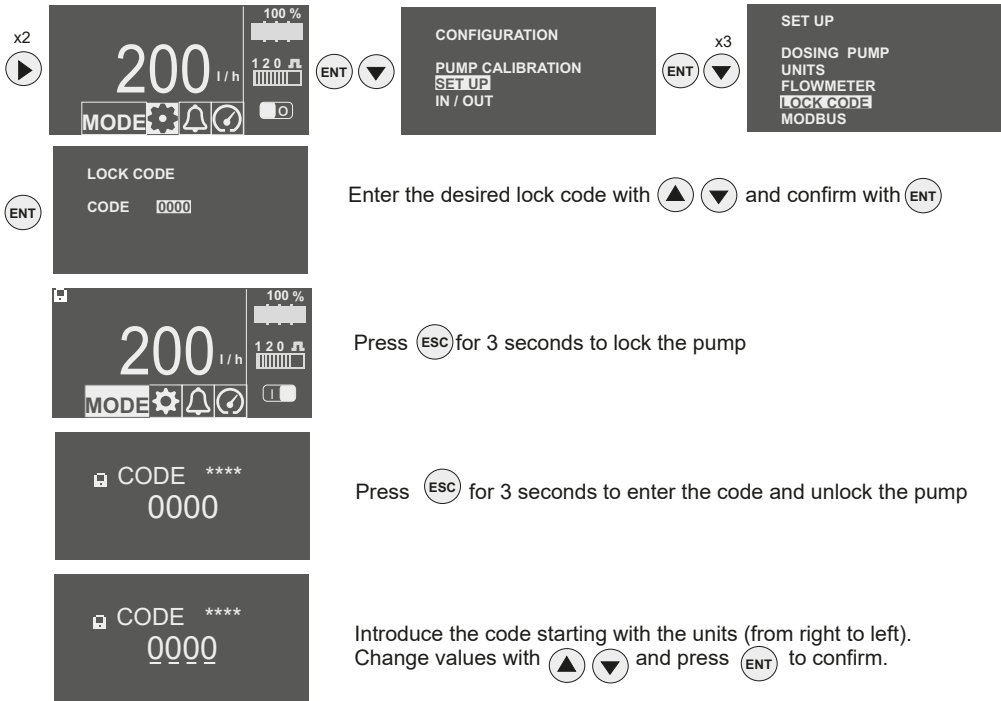

4.2.2.5 ModBus

Introduce the device address for a ModBus communication (1-128)

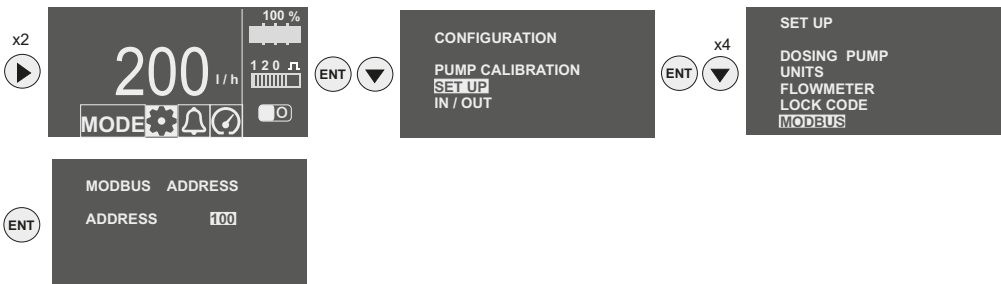



4.2.3. IN / OUT

4.2.3.1 Pressure input

Calibration of the pressure transducer input 4-20mA input

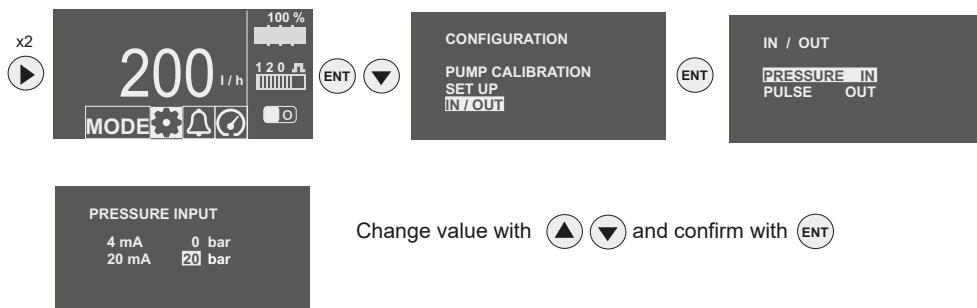

4.2.3.2 Pulse output

Configuration of the output pulses per stroke to monitor or drive a second pump

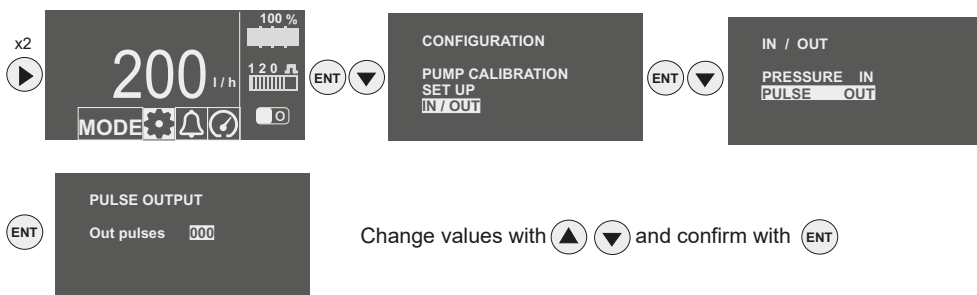

4.2.3.3 4-20mA output

4-20mA output to monitor.

Configuración:

4 mA for 0% flow
 20mA for 100% flow



4.3 ALARM

4.3.1 Level alarm 1

Level alarm for tank pre-empty

x3

ENT

ENT

LEVEL 1 PRE EMPTY

Alarm	OFF
Level relay	OFF
Stop pump	OFF

Enable or disable the pre-empty level alarm with and confirm with **ENT**

LEVEL 1 PRE EMPTY

Alarm	ON
Level relay	OFF
Stop pump	OFF

Switch on the Alarm Level relay when alarm is on and confirm with **ENT**

LEVEL 1 PRE EMPTY

Alarm	ON
Level relay	ON
Stop pump	OFF

Stop the pump when alarm is on and confirm with **ENT**

4.3.2 Level alarm 2

Level alarm for tank empty

x3

ENT

ENT

LEVEL 2 EMPTY

Alarm	OFF
Level relay	OFF
Stop pump	OFF

Enable or disable the alarm with and confirm with **ENT**

LEVEL 2 EMPTY

Alarm	ON
Level relay	OFF
Stop pump	OFF

Switch on the Alarm Level relay when alarm is on and confirm with **ENT**

LEVEL 2 EMPTY

Alarm	ON
Level relay	ON
Stop pump	OFF

Stop the pump when alarm is on and confirm with **ENT**



4.3.3 Flow failure alarm

Alarm is on when the unit doesn't receive any pulse from the flow detector in 40 strokes of the pump

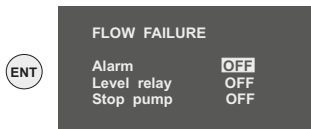
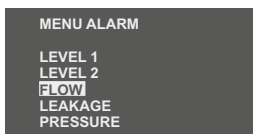
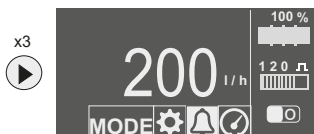

Enable or disable the alarm with and confirm with

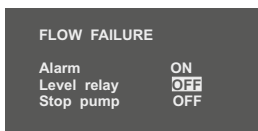

Switch on the Alarm Level relay when alarm is on and confirm with

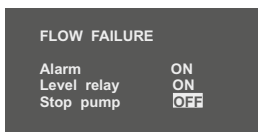

Stop the pump when alarm is on and confirm with

4.3.4 Diaphragm leakage alarm

Alarm to detect a diaphragm leakage in electric conductive media (min. 0.05mS)

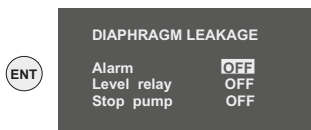
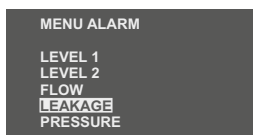
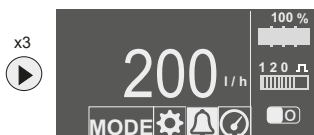

Enable or disable the empty level alarm with and confirm with

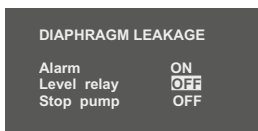

Switch on the Alarm Level relay when alarm is on and confirm with

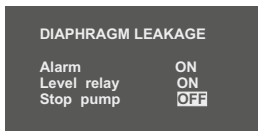

Stop the pump when alarm is on and confirm with



4.3.5 Overpressure alarm

Alarm to detect overpressure

x3

x4

Enable or disable the empty level alarm with and confirm with

Switch on the Alarm Level relay when alarm is on and confirm with

Stop the pump when alarm is on and confirm with

4.4 MONITOR

4.4.1 Real Time

Real time working parameters

x4

- Analogue input value (mA)
- External pulse input value (Hz)
- Pressure sensor input value (BAR/ PSI)
- External pulse input value
- Remote Activation input
- Encoder pulse input value

- Analog output value (mA)
- External pulse output value (pulse/ min)
- Level sensor alarm output
- Alarm output
- Ventilation output

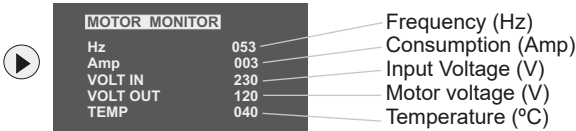

4.4.2 Counters

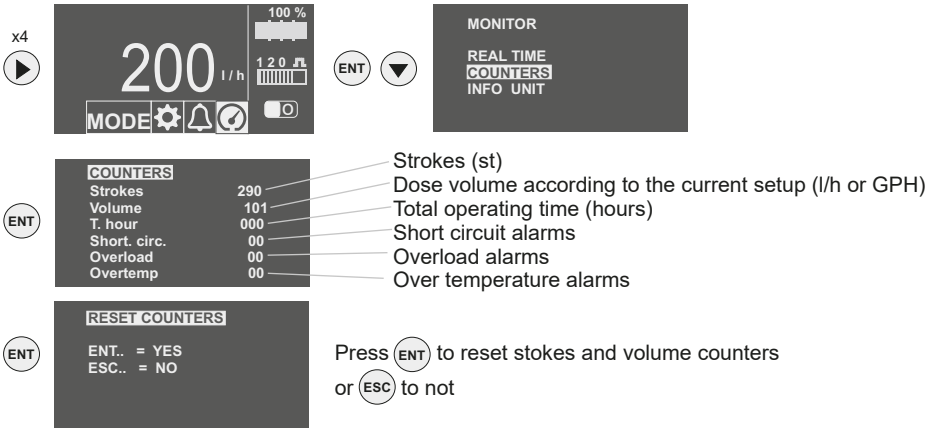

4.4.3 INFO UNIT

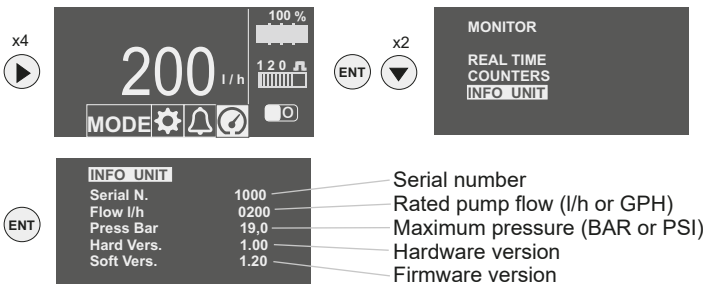



5.- INSTALLATION

5.1.- GENERALITIES

To install this pump it is advisable to choose places protected from water, away from heat sources and with air renewal.

Place the pump vertically over a totally rigid surface to achieve a proper lubrication of all inner elements. Anticipate which will be the room you will need to comfortably do the basic maintenance and install / uninstall the pump.

Fix the pump on the chosen flat surface by means of 4 screws.

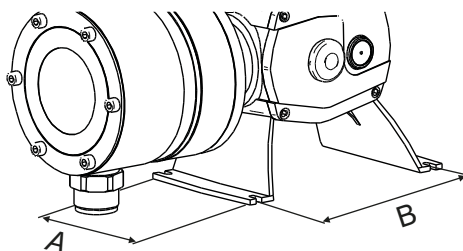

	A	B	
AC3	90	155	mm
	3.5	6.1	in
AC2 /1	122	212	mm
	4.8	8.3	in

5.2.- BLOCK

Pull out the oil cap for transport , fill the pump with the SAE oil 80W90 being supplied (or similar oil), up to the level shown on the screen and put on the working cap (black with a hole).

Approximate oil contents 650 cm³

Oil list:

- CEPSA SAE80W90
- REPSOL EP 80W/90
- SHELL SPIRLAXHD OIL 80W/90
- ESSO GEAR OIL 80W/90
- AGIP ROTRA MP 80W-90
- MOBILUDE HD 80W-90
- BP ENERGEAR HT 80W-90
- CATROL HYPOYC
- GULF GEAR MP SAE 80W 90
- ELF TRANSGEAR HD 80W-90

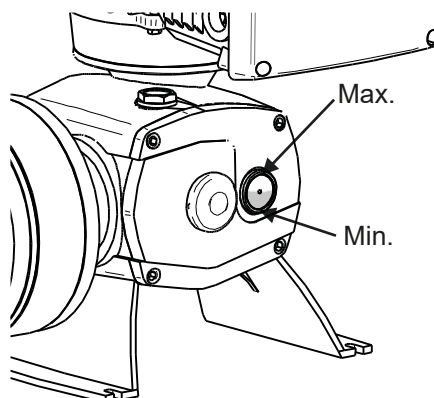



5.3.- ELECTRICAL CONNECTION



The electric protection of the motor must be installed and adjusted following its nominal intensity (overloaded switch disjuntor). (See wiring).

A disconnection dispositive must be installed in case of emergency.

The equipment must be protected to avoid unexpected sudden starts.

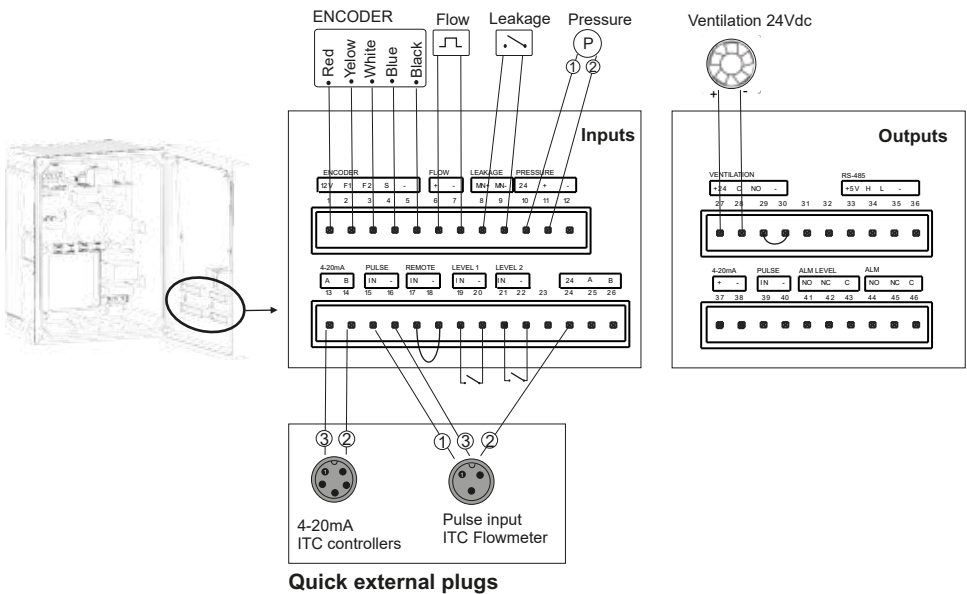
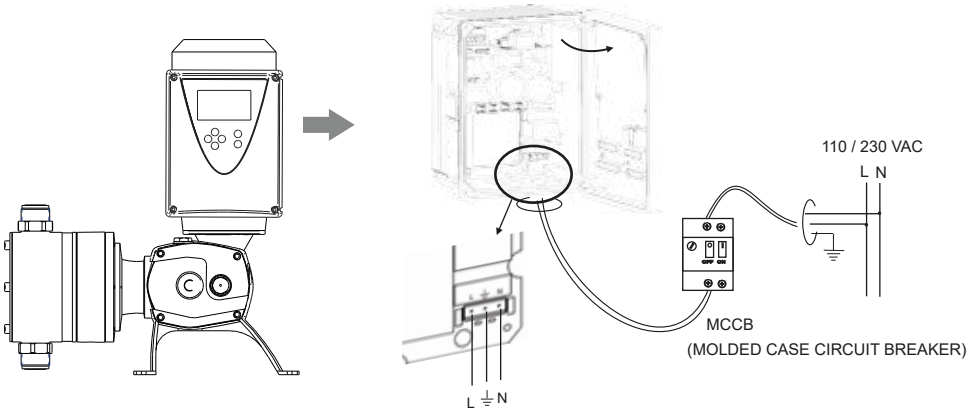



WIRING

Inputs

N	FUNCTION	DETAIL
1	Encoder	+12vdc
2	Encoder	F1
3	Encoder	F2
4	Encoder	S
5	Encoder	(-)
6	Flow detector	(+)
7	Flow detector	(-)
8	Leakage detector	(+)
9	Leakage detector	(-)
10	Pressure transmitter	+24v dc
11	Pressure transmitter	(+)
12	Pressure transmitter	(-)
13	Analogue mode input 4-20mA	(+)
14	Analogue mode input 4-20mA	(-)
15	Proportional mode pulse input	Pulse
16	Proportional mode pulse input	(-)
17	Remote activation / Batch mode	Dry contact
18	Remote activation / Batch mode	Dry contact
19	Level sensor 1	Dry contact
20	Level sensor 1	Dry contact
21	Level sensor 2	Dry contact
22	Level sensor 2	Dry contact

Outputs

27	Additional ventilation	+24v dc
28	Additional ventilation	Relay Output Common
29	Additional ventilation	Relay Output NO
30	Additional ventilation	(-)
33	RS-485	+5Vdc
34	RS-485	H (+ A)
35	RS-485	L (- B)
36	RS-485	(-)
37	Analog monitor output 4-20mA	(+) Not optically isolated
38	Analog monitor output 4-20mA	(-) Not optically isolated
39	Pulse monitor output	Signal. Not optically isolated
40	Pulse monitor output	(-) Not optically isolated
41	Level alarm output	NO
42	Level alarm output	NC
43	Level alarm output	Common (max.5Amp 250VAC)
44	Alarm output	NO
45	Alarm output	NC
46	Alarm output	Common (max.5Amp 250VAC)



5.4.- HYDRAULIC INSTALLATION

5.4.1- Installation examples

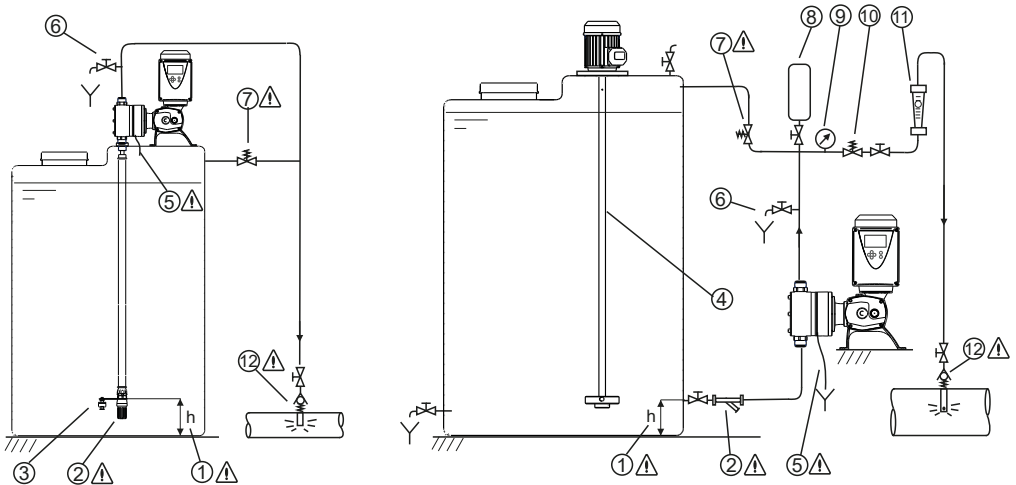

- ⚠ ① Avoid suctioning the undiluted particles from the bottom of the tank.
- ⚠ ② Filter. It is important to install a filter (150 micron) in the suction pipe.
- ③ Level sensor
- ④ Agitator
- ⚠ ⑤ Make sure to collect any liquid leakage from the cylinder's vent/drain hole in a proper container.
- ⑥ Prime valve / drain valve
- ⚠ ⑦ Safety relief valve. Install a safety valve in a derivation as near as possible from the pump, in order to protect it and the whole installation from possible over-pressures. This derivation must derive liquid to a safe place.
- ⑧ Pulsation dampener
- ⑨ Pressure gauge
- ⑩ Pressure regulating valve
- ⑪ Flowmeter
- ⚠ ⑫ Injection check valve



5.4.2.- Recomendations for the correct installation

SUCTION PIPE

⚠ Long suction pipe: $L > 2\text{m}$ (6.5ft)

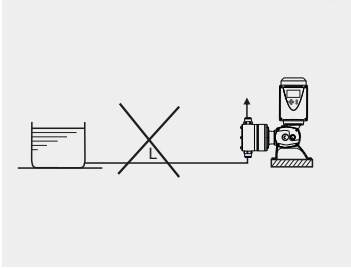

RECOMMENDED PIPE SIZE			
Øint	$L \leq 2\text{ m}$	$L \leq 5\text{ m}$	
6	50	25	
15	300	100	
20		200	
25		300	
30	800	500	
40	1000	800	
50		850	
60		900	
70		1000	
Q max (l/h)			

⚠ Air in suction pipe

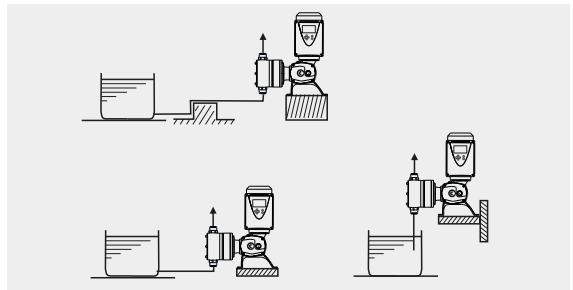
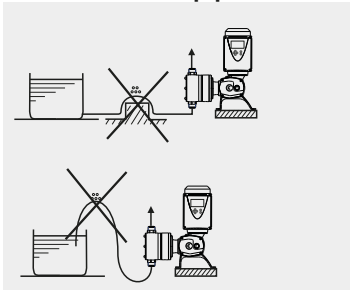

DISCHARGE PIPE

⚠ Long discharge pipe: $L > 5\text{m}$ (16 ft)

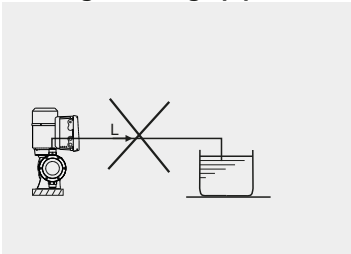

RECOMMENDED PIPE SIZE			
Øint	$L \leq 2\text{ m}$	$L \leq 10\text{ m}$	
6	80	10	
15	300	70	
20		100	
25		200	
30		300	
30	1000		
40		400	
50		600	
60		1000	
Q max (l/h)			

⚠ Siphon

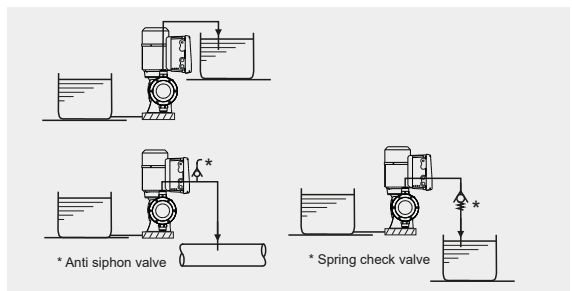
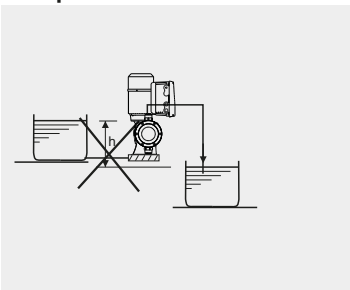



5.5.- ACCESSORIES

5.5.1- Diaphragm leakage detector

The diaphragm leakage detector is a conductivity sensor which is able to detect conductive liquids, with a minimum conductivity of 0.05mS. The pump must be provided with the specific diaphragm flange to hold the leakage detector.

Ø diaphragm	Standard flange
69	29-063-P
95	29-064-P
115	29-065-P
142	29-066-P
163	29-067-P

Fit the leakage detector Ref. 29-056 in the bottom hole of the diaphragm flange and connect it in pins 8 - 9, as shown in the drawing

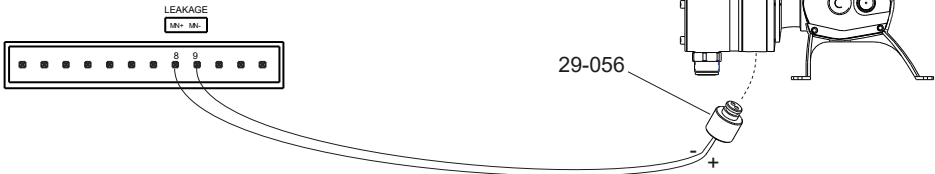

5.5.2- Flow detector

The flow detector is a device, which monitors the pulsated delivered flow. The pulses are received and processed by the Advance Control Unit in order to detect dosing failures like not priming, cavitation or check valves problems. The unit compares the strokes of the pump with the pulses from the detector. When the pump does 40 strokes with no signal from the flow detector and alarm can be activated.



5.5.3- Pressure sensor

The pressure sensor protects the pump against overpressure when the pressure alarm is activated. Connect the pressure sensor 4-20mA 10Bar Ref. 18705 as shown in the drawing





5.5.4- Additional ventilation 115 / 230V

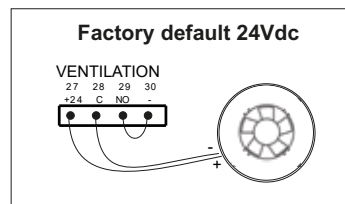
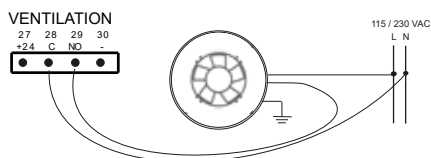

6.- START UP AND REGULATION



STAND: Check that the pump is properly installed in its stand.



OIL: Take off re-filling lid and fill the pump with the provided oil: SAE 80 W 90 or equivalent.
Check the oil level shown on the oil peep hole

Lubricants list:

CEPESA SAE 80W 90
 REPSOL EP 80W/90
 SHELL SPIRLAX HD OIL 80W/90
 ESSO GEAR OIL 80W/90
 AGIP ROTRA MP 80W-90
 MOBILUDE HD 80W-90
 BP ENERGEAR HT 80W-90
 CASTROL HYPOYC
 GULF GEAR MP SAE 80W 90
 ELF TRANSGEAR HD 80W-90



CHECKING THE HYDRAULIC CIRCUIT: Check that all valves are opened and that escapes from priming valves derive the liquid to a proper receptacle.



CHECKING OF PUMP: Check visually/auditorilly the proper working of the pump.

7.- MAINTENANCE

AC3 PISTON

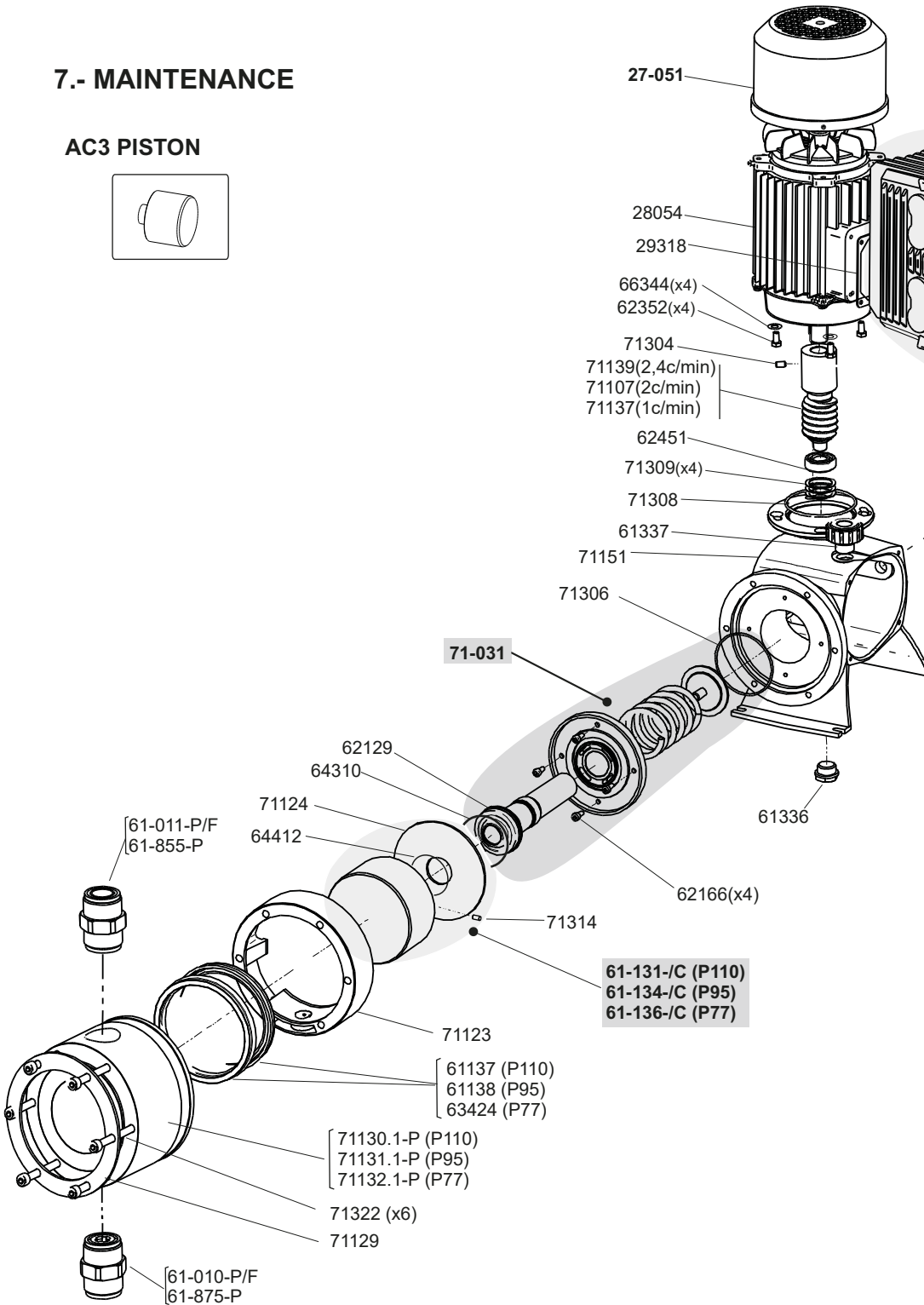
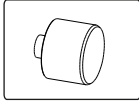

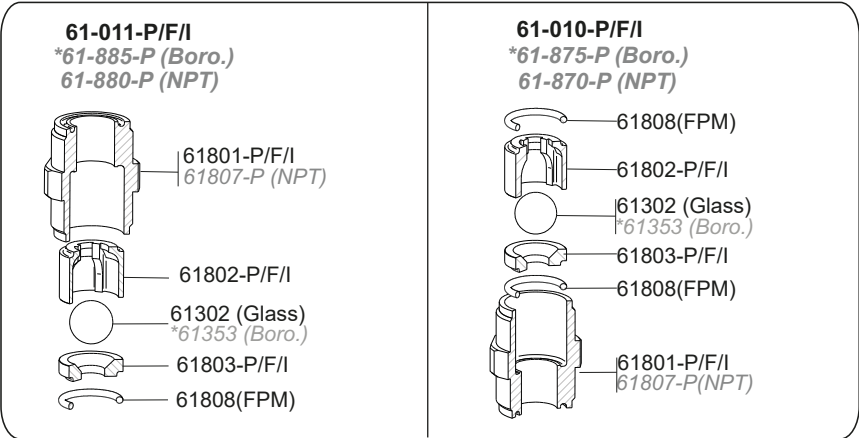
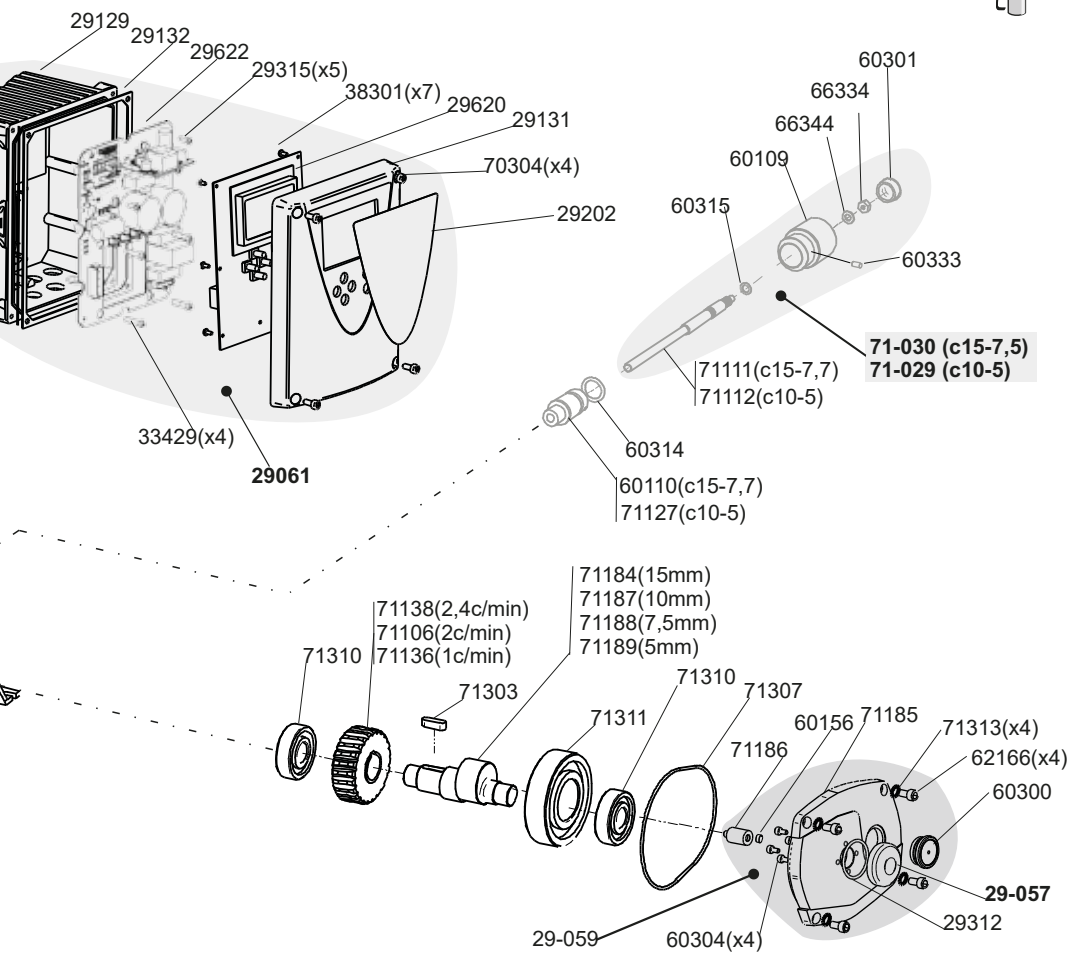

LIST OF PARTS AC3 (Piston)



CODE	DESCRIPTION	UNITS
28054	Electric motor 1,2Kw 6P 110/190 3ph 80/100 B14	1
29129	Advanced Control case	1
29131	Advanced Control lid	1
29132	Case seal DOSTEC AC	1
29202	Lexan Dostec AC	1
29312	O-ring 32x2 FPM	1
29315	Screw M3x12 Din7985 ss	5
29318	Seal motor inverter 83x83	1
29620	Control board AC	1
29622	Power board 230V AC	1
33429	Screw M4x20 Din 912 a-2	4
38301	Screw M3x8 Din7985 A2	7
60109	Regulator knob Dostec	1
60110	Regulator guide p1,5mm Dostec	1
60156	Magnet for encoder d6x2.5	1
60300	Oil peep hole	1
60301	Regulator knob plug	1
60304	Screw M4x8 Din 912 A4	4
60314	O-ring 17x3,5 NBR	1
60315	O-ring 6,5x2 NBR	1
60333	Screw M4x8 DIN 913 A-2	1
61-131/-C	Piston 1000 l/h D110 lock EF	1
61-134/-C	Piston 750 l/h D95 lock EF	1
61-136/-C	Piston 500 l/h D77 lock EF	1
61137	Seal 1000 l/h FPM	2
61138	Seal 750 l/h FPM	2
61336	Drain plug ½	1
61337	Filler plug ½"	1
62129	Bellow FPM	1
62166	Screw M6x16 Din 912 A2	8
62352	Screw M6x12 Din 933 A2	4
62451	Bearing 6202 zz	1
63424	Seal 78x87x6 FPM 500 l/h	2
64310	O-ring 55,5x3,5 NBR	1
64412	O-ring 44x2 FPM	1
66334	Nut M6 Din 934 A2	1
66344	Washer D6 Din 125 A2	5
70304	Screw M5x20 Din 912 I	4
71106	Ring gear 2 stroke D50	1
71107	Pinion 2 stroke D50	1
71111	Regulation rod p1,5mm D50	1
71112	Regulation rod p1 mm D50	1
71123	Cylinder spacer D50	1
71124	Protection disc D50	1
71127	Regulation guide p 1mm D50	1
71129	Ring plate for piston cylinder	1



71130.1-P	Cylinder 1000 l/h s ring plate PP	1
71131.1-P	Cylinder 750 l/h s ring plate PP	1
71132.1-P	Cylinder 500 l/h s ring plate PP	1
71136	Ring gear 1 stroke D50	1
71137	Pinion 1 stroke D50	1
71138	Ring gear 2,4 stroke D50	1
71139	Pinion 2,4strokes D50	1
71129	Ring plate for piston cylinder D160	1
71151	Block D50 Ac3	1
71184	Eccentric shaft 15 encoder Ac3	1
71185	Block lid D50 encoder	1
71186	Magnet for encoder base D50	1
71187	Eccentric shaft 10 encoder Ac3	1
71188	Eccentric shaft 7,5 encoder Ac3	1
71189	Eccentric shaft 5 encoder Ac3	1
71303	Wedging piece Din 6885-a (8x7x25)	1
71304	Screw M6x10 Din 913 8.8	1
71306	O-ring 70 x 2,5 NBR	1
71307	O-ring 125x2,5 NBR	1
71308	O-ring 77 x 2 NBR	1
71309	Elastic washer Din137-b (34x26x0,4)	3
71310	Bearing 6304zz (20x52x15)	2
71311	Bearing 6308zz (40x90x23)	1
71313	washer M6 Nord-lock	4
71314	Screw M5x12 DIN914 A2	1
71322	Tornillo M8x150 DIN912 A2	6

ASSEMBLIES

27-051	Additional ventilation 24v D50/ EF low presure	1
29-057	PCB and base encoder DOSTEC AC	1
29-059	Encoder Ac3 (doetec50)	1
29061	Advance Control AC2/3 230Vac	1
71-029	Regulator p 1mm D50 assembly	1
71-030	Regulator p 1,5 mm D50 assembly	1
71-031	Rod slider D50-P assembly	1

VALVES

61-010-P/F/I	Suction check valve 1 1/4	1
61-011-P/F/I	Discharge check valve 1 1/4	1
61-875-P/	Suction check valve 1 1/4 PP Borosilicate	1
61-085-P	Discharge check valve 1 1/4 PP Borosilicate	1

MAINTENACE KIT (valves+seals+bellow)

71-071-P	Maintenance kit Dostec-50 P77 PP	1
71-072-P	Maintenance kit Dostec-50 P95 PP	1
71-073-P	Maintenance kit Dostec-50 P110 PP	1

Materials code: -P= Polypropylene
-F= PVDF
-I= SS 316
-C= ceramic

AC3 DIAPHRAGM

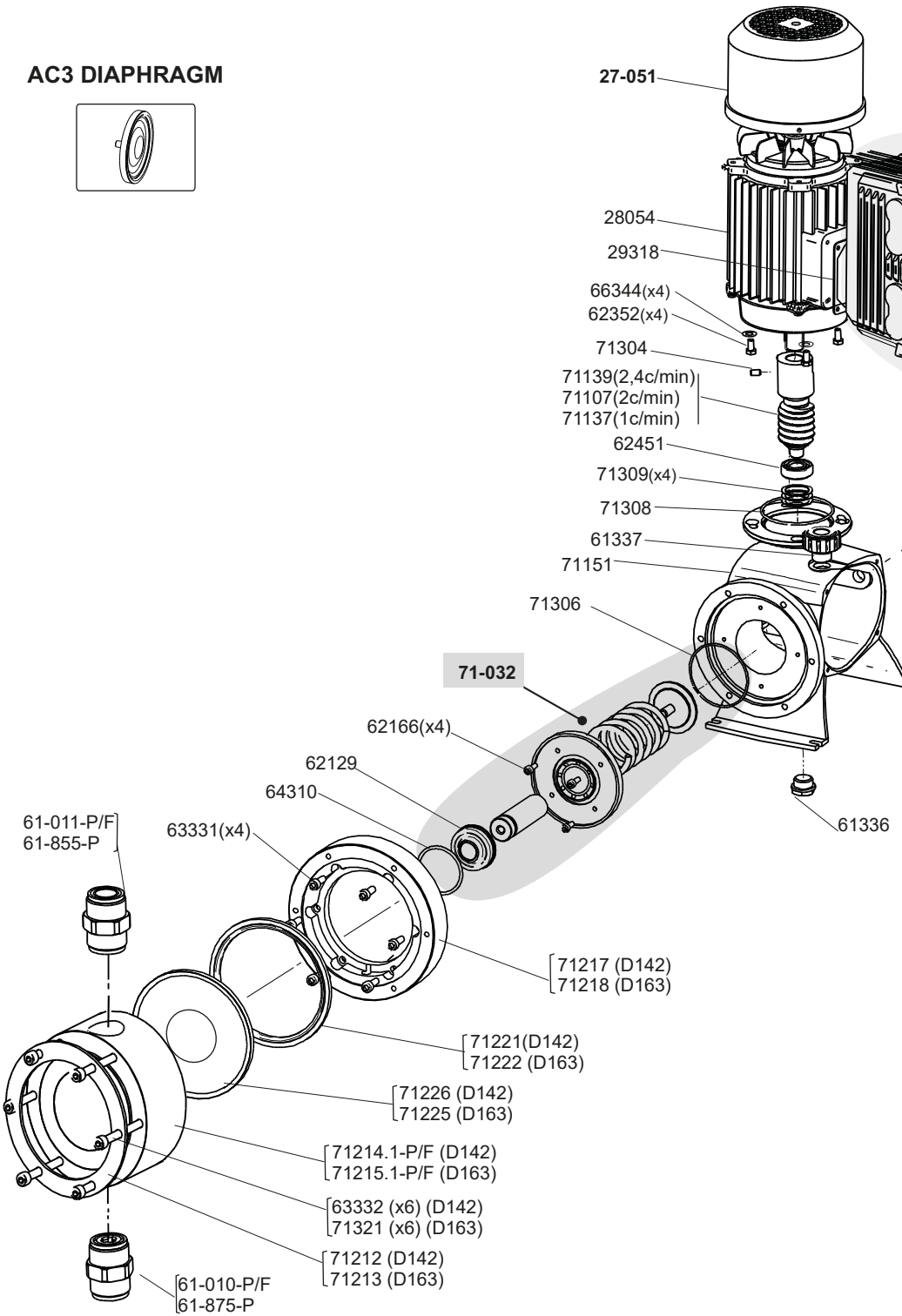
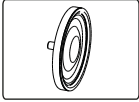

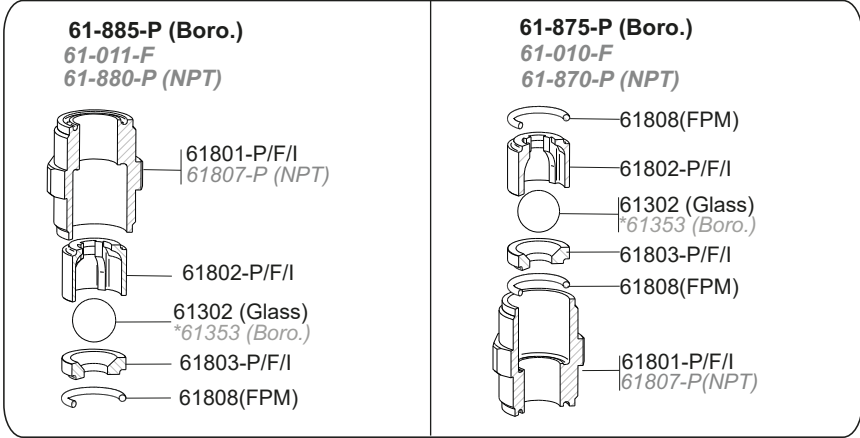
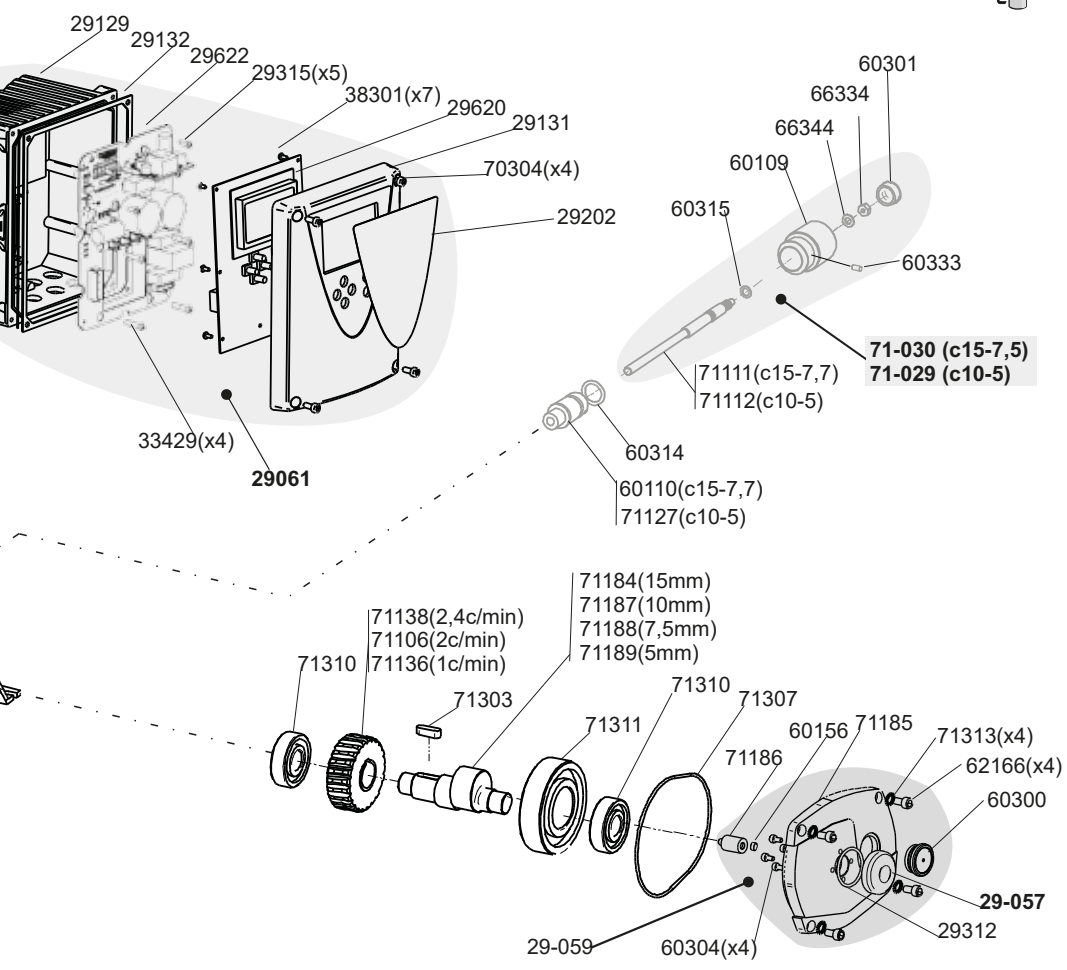



LIST OF PARTS AC3 (Diaphragm)

CODE	DESCRIPTION	UNITS
28054	Electric motor 1,2Kw 6P 110/190 3ph 80/100 B14	1
29129	Advanced Control case	1
29131	Advanced Control lid	1
29132	Case seal DOSTEC AC	1
29202	Lexan Dostec AC	1
29312	O-ring 32x2 FPM	1
29315	Screw M3x12 Din7985 ss	5
29318	Seal motor inverter 83x83	1
29620	Control board AC	1
29622	Power board 230V AC	1
33429	Screw M4x20 Din 912 a-2	4
38301	Screw M3x8 Din7985 A2	7
60109	Regulator knob Dostec	1
60110	Regulator guide p1,5mm Dostec	1
60156	Magnet for encoder d6x2.5	1
60300	Oil peep hole	1
60301	Regulator knob plug	1
60304	Screw M4x8 Din 912 A4	4
60314	O-ring 17x3,5 NBR	1
60315	O-ring 6,5x2 NBR	1
60333	Screw M4x8 DIN 913 A-2	1
61336	Drain plug ½	1
61337	Filler plug ½"	1
62129	Bellow FPM	1
62166	Screw M6x16 Din 912 A2	8
62352	Screw M6x12 Din 933 A2	4
62451	Bearing 6202 zz	1
63331	Screw M8x20 Din 912 A2	6
63332	Screw M8x90 Din 912 A2	6
64310	O-ring 55,5x3,5 NBR	1
66334	Nut M6 Din 934 A2	1
66344	Washer D6 Din 125 A2	5
70304	Screw M5x20 Din 912 I	4
71106	Ring gear 2 stroke D50	1
71107	Pinion 2 stroke D50	1
71111	Regulation rod p1,5mm D50	1
71112	Regulation rod p1 mm D50	1
71127	Regulation guide p 1mm D50	1
71136	Ring gear 1 stroke D50	1
71137	Pinion 1 stroke D50	1
71138	Ring gear 2,4 stroke D50	1
71184	Eccentric shaft 15 encoder Ac3	1
71185	Block lid D50 encoder	1
71186	Magnet for encoder base D50	1
71187	Eccentric shaft 10 encoder Ac3	1



71188	Eccentric shaft 7,5 encoder Ac3	1
71189	Eccentric shaft 5 encoder Ac3	1
71139	Pinion 2,4strokes D50	1
71212	Ring plate for diaphragm cylinder D142	1
71213	Ring plate for diaphragm cylinder D163	1
71214.1-P/F	Cylinder diaphragm ring plate D142	1
71215.1-P/F	Cylinder diaphragm ring plate D163	1
71217	Diaphragm flange D142	1
71218	Diaphragm flange D163	1
71221	Base membrana D142	1
71222	Base membrana D163	1
71225	Diaphragm D163	1
71226	Diaphragm D142	1
71303	Wedging piece Din 6885-a (8x7x25)	1
71304	Screw M6x10 Din 913 8.8	1
71306	O-ring 70 x 2,5 NBR	1
71307	O-ring 125x2,5 NBR	1
71308	O-ring 77 x 2 NBR	1
71309	Elastic washer Din137-b (34x26x0,4)	3
71310	Bearing 6304zz (20x52x15)	2
71311	Bearing 6308zz (40x90x23)	1
71313	washer M6 Nord-lock	4
71321	Screw M8x100 Din 912 A2	6

ASSEMBLIES

27-051	Additional ventilation 24v D50/ EF low presure	1
29-057	PCB and base encoder DOSTEC AC	1
29-059	Encoder AC3 (doetec50)	1
29061	Advance Control AC2/3 230Vac	1
71-029	Regulator p 1mm D50 assembly	1
71-030	Regulator p 1,5 mm D50 assembly	1
71-032	Rod slider D50-D assembly	1

VALVES

61-010-F	Suction check valve 1 1/4 PVDF	1
61-011-F	Discharge check valve 1 1/4 PVDF	1
61-875-P	Suction check valve 1 1/4 PP Borosilicate	1
61-085-P	Discharge check valve 1 1/4 PP Borosilicate	1

MAINTENACE KIT (valves+diaphragm+bellow)

71-075-P	Maintenance kit Dostec-50 D142 PP
71-076-P	Maintenance kit Dostec-50 D163 PP

Materials code: -P= Polypropylene
-F= PVDF
-I= SS 316

AC1/2 PISTON

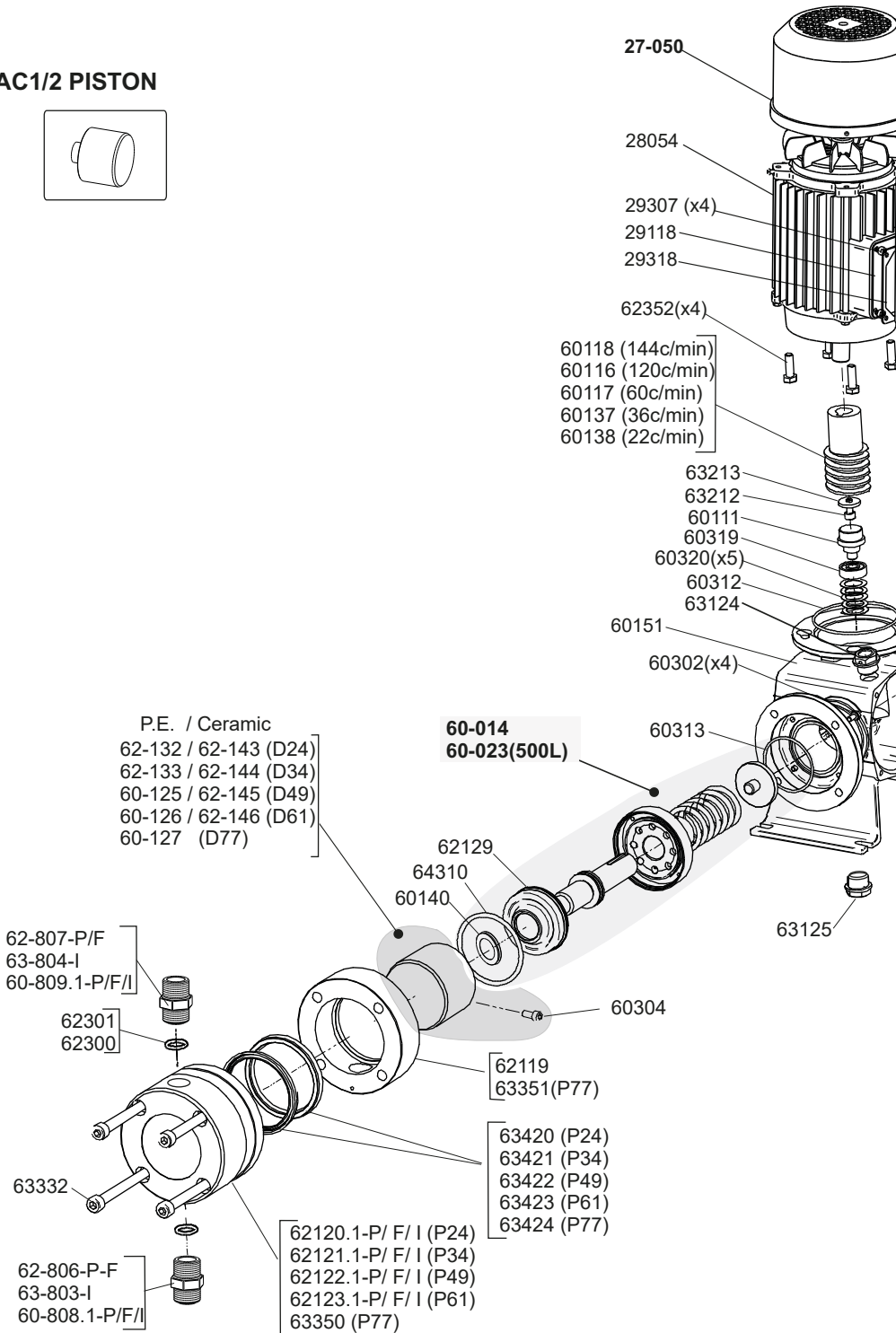
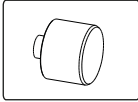

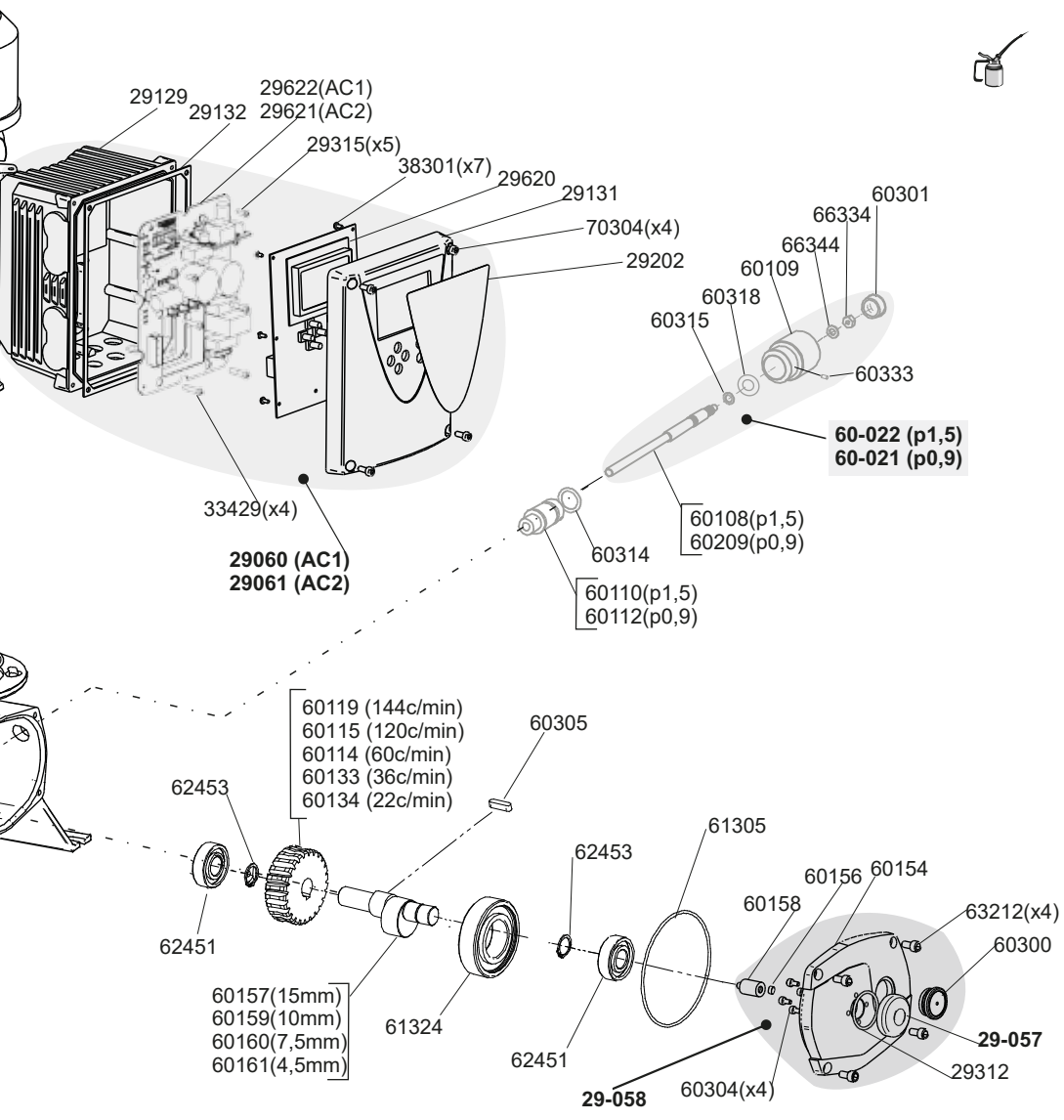



LIST OF PARTS AC1/2 (Piston)

Code	Description	Units
28053	Motor 230Kw AC1/2	1
29118	Motor adapter for inverter 0,5Hp 110V	1
29129	Advanced Control case	1
29131	Advanced Control lid	1
29132	Case seal DOSTEC AC	1
29202	Lexan Dostec AC	1
29307	Screw M4x15 Din 7991	4
29312	O-ring 32x2 FPM	1
29315	Screw M3x12 Din7985 ss	5
29318	Seal motor inverter 83x83	1
29620	Control board AC	1
29621	Power board 110V AC	1
29622	Power board 230V AC	1
33429	Screw M4x20 Din 912 a-2	4
38301	Screw M3x8 Din7985 A2	7
60108	Regulation rod 15 Dostec	1
60109	Regulator knob Dostec	1
60110	Regulator guide p1,5mm Dostec	1
60111	Pinion bumper Dostec	1
60112	Dostec guide regulator p0,9mm	1
60114	Ring gear 1 strokes/s D40	1
60115	Ring gear 2 strokes/s D40	1
60116	Pinion 2 strokes/s D40-MF	1
60117	Pinion 2 strokes/s D40-MF	1
60118	Pinion 2.4 strokes/s D40-MF	1
60119	Ring gear 2,4 strokes/s D40	1
60-125	Piston 200 l - s M20 lock	1
60-126	Piston 300 l - s M20 lock	1
60-127	Piston 500 l M20	1
60133	Ring gear 0.6 stroke/s D40	1
60134	Ring gear 0.3 stroke/s D40	1
60137	Pinion 0.6 stroke/s D40	1
60138	Pinion 0.3 stroke/s D40	1
60140	Rod protective D40	1
60151	Block D40 AC1/2	1
60154	Block lid encoder AC1-2	1
60156	Magnet for encoder d6x2.5	1
60157	Eccentric shaft 15 encoder AC1-2	1
60158	Encoder's magnet base AC1-2	1
60159	Eccentric shaft 9 encoder AC1-2	1
60160	Eccentric shaft 7,5 encoder AC1-2	1
60161	Eccentric shaft 4,5 encoder AC1-2	1
60209	Diaphragm regulation rod Dostec	1
60300	Oil peep hole	1
60301	Regulator knob plug	1
60302	Screw M4x8 Din 933 A2	4
60304	Screw M4x8 Din 912 A4	4
60305	Wedging piece Din 6885-a 5x5x20	1
60312	O-ring 68x1,5 NBR	1
60313	O-ring 44x2 NBR	1
60314	O-ring 17x3,5 NBR	1
60315	O-ring 6,5x2 NBR	1
60318	Washer D8 Din 125 A2	1
60319	Bearing 608-zz (8x22x7)	1
60320	Elastic washer din137-b(21x10.5x1)	5
60333	Screw M4x8 DIN 913 A-2	1
61305	O-ring 88x2,5 NBR	1



61324	Bearing 6206zz (30x62x16) EF	1
62119	Cylinder spacer D40/MF	1
62120.1-P/F/I	Cylinder 50 l/h - s 3/4'	1
62121.-P/F/I	Cylinder 100 l/h - s 3/4'	1
62122.1-P/F/I	Cylinder 200 l/h - s 3/4'	1
62123.1--P/F/I	Cylinder 300 l/h - s 3/4'	1
62129	Bellow FPM	1
62-132	Piston 50 l/h - s M20 lock	1
62-133	Piston 100 l/h - s M20 lock	1
62-143	Piston 50 l/h - s M20 lock ceramic	1
62-144	Piston 100 l/h - s M20 lock ceramic	1
62-145	Piston 200 l/h - s M20 lock ceramic	1
62-146	Piston 300 l/h - s M20 lockceramic	1
62300	O-ring 19x3 FPM	2
62301	O-ring 19x3 NBR	2
62352	Screw M6x12 Din 933 A2	4
62451	Bearing 6202 zz	2
62453	Retaining ring 15 Din 471	2
63124	filler plug	1
63125	3/8" drain plug	1
63212	Screw M5x12 Din 912 A2	5
63213	Washer 18x5x2,5 F5	1
63332	Screw M8x90 Din 912 A2	4
63350	Cylinder 500 l/h	1
63351	500l electro flange	1
63420	Seal 25x34x6 FPM 50 l/h	2
63421	Seal 35x45x6 FPM 100 l/h	2
63422	Seal 50x60x6 FPM 200 l/h	2
63423	Seal 60x68x6 FPM 300 l/h	2
63424	Seal 78x87x6 FPM 500 l/h	2
64310	O-ring 55,5x3,5 NBR	1
66334	Nut M6 Din 934 A2	1
66344	Washer D6 Din 125 A2	1
70304	Screw M5x20 Din 912 I	4

ASSEMBLIES

27-050	Additional ventilation 24vdc IP56 DOSTEC AC1-2	1
29-057	PCB and base encoder DOSTEC AC	1
29-058	Encoder AC1-2 (dostec40)	1
29060	Advance Control AC1 110Vac	1
29061	Advance Control AC2/3 230Vac	1
60-014	Rod slider D40-P assembly	1
60-021	Regulator p 0,9 mm D40 assembly	1
60-022	Regulator p 1,5 mm D40 assembly	1
60-023	Rod slider D40-P 500 l/h assembly	1

VALVES

60-808.1-P/F/I	Suction check valve hose 6X12 3/4	1
60-809.1-P/F/I	Discharge check valve hose 6X12 3/4	1
62-806-P/F	Suction check valve 3/4	1
62-807-P/F	Discharge check valve 3/4	1
63-803-I	Suction check valve 3/4 s.s.	1
63-804-I	Discharge check valve 3/4 s.s.	1
60-814.1-P/F/I	Priming valve 3/4 max. 50 l/h	1
60-840-P/F/I	Priming valve 3/4 max. 500 l/h	1

MAINTENANCE KIT

60-071-P	Maintenance kit Dostec-40 P24 PP
60-072-P	Maintenance kit Dostec-40 P34 PP
60-073-P	Maintenance kit Dostec-40 P49 PP
60-074-P	Maintenance kit Dostec-40 P61 PP
60-075-P	Maintenance kit Dostec-40 P77 PP

Materials code: -P= Polypropylene
-F= PVDF
-I= SS 316

AC1/2 DIAPHRAGM

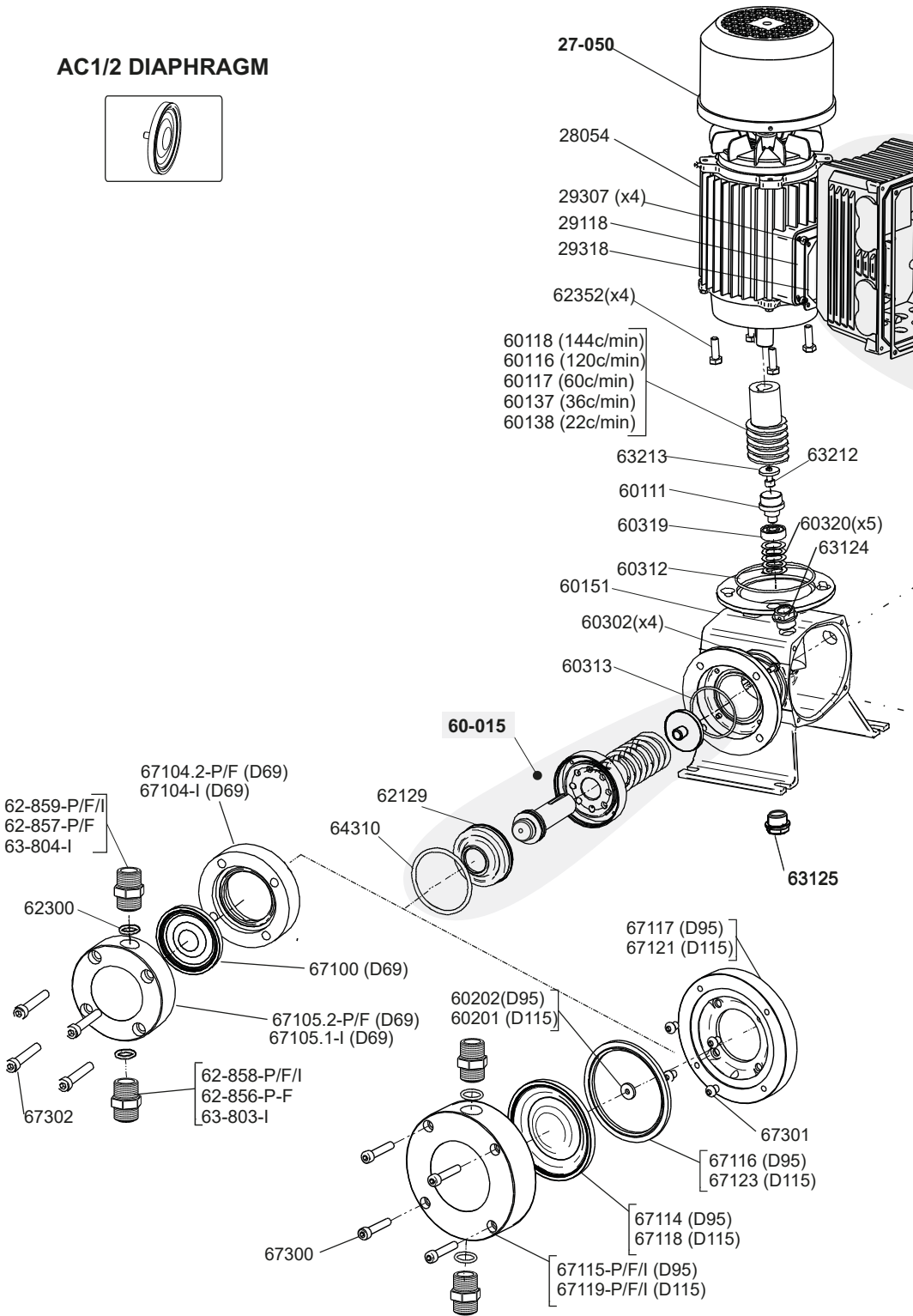
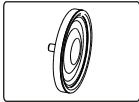

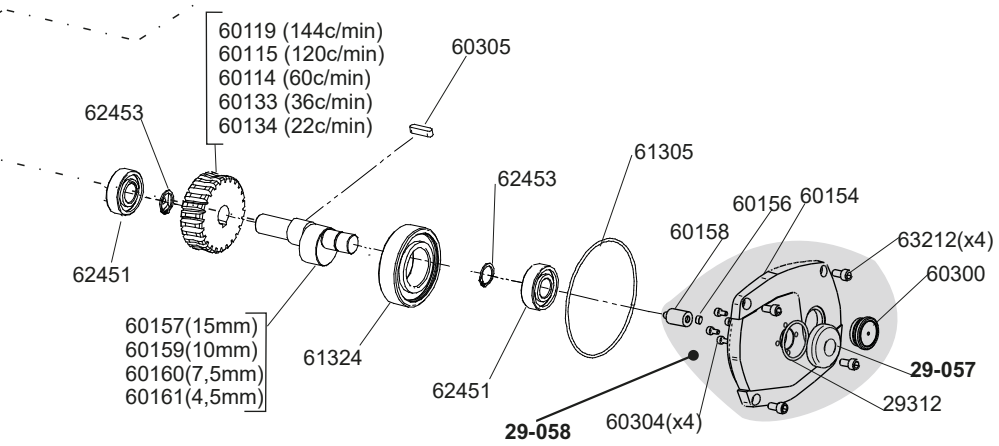
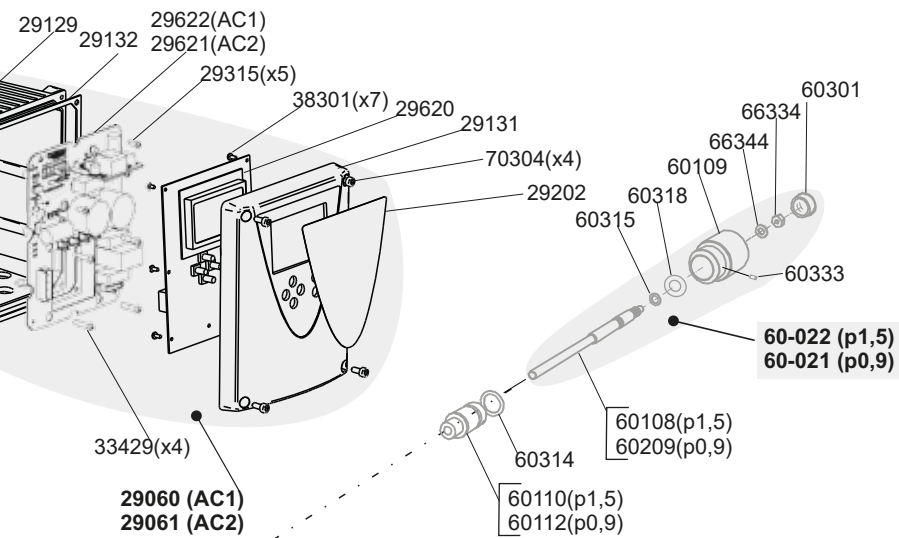

LIST OF PARTS AC1/2 (Diaphragm)



Code	Description	Units
28053	Motor 230Kw AC1/2	1
29118	Motor adapter for inverter 0,5Hp 110V	1
29129	Advanced Control case	1
29131	Advanced Control lid	1
29132	Case seal DOSTEC AC	1
29202	Lexan Dostec AC	1
29307	Screw M4x15 Din 7991	4
29312	O-ring 32x2 FPM	1
29315	Screw M3x12 Din7985 ss	5
29318	Seal motor inverter 83x83	1
29620	Control board AC	1
29621	Power board 110V AC	1
29622	Power board 230V AC	1
33429	Screw M4x20 Din 912 a-2	4
38301	Screw M3x8 Din7985 A2	7
60104	Eccentric shaft 15	1
60108	Regulation rod 15 Dostec	1
60109	Regulator knob Dostec	1
60110	Regulator guide p1,5mm Dostec	1
60111	Pinion bumper Dostec	1
60112	Dostec guide regulator p0,9mm	1
60114	Ring gear 1 strokes/s D40	1
60115	Ring gear 2 strokes/s D40	1
60116	Pinion 2 strokes/s D40-MF	1
60117	Pinion 2 strokes/s D40-MF	1
60118	Pinion 2.4 strokes/s D40-MF	1
60119	Ring gear 2.4 strokes/s D40	1
60133	Ring gear 0.6 stroke/s D40	1
60134	Ring gear 0.3 stroke/s D40	1
60137	Pinion 0.6 stroke/s D40	1
60138	Pinion 0.3 stroke/s D40	1
60151	Block D40 AC1/2	1
60154	Block lid encoder AC1-2	1
60156	Magnet for encoder d6x2.5	1
60157	Eccentric shaft 15 encoder AC1-2	1
60158	Encoder's magnet base AC1-2	1
60159	Eccentric shaft 9 encoder AC1-2	1
60160	Eccentric shaft 7,5 encoder AC1-2	1
60161	Eccentric shaft 4,5 encoder AC1-2	1
60201	Washer spacer diaphragm D115 (black) D40	1
60202	Washer spacer diaphragm D95 (red) D40	1
60209	Diaphragm regulation rod Dostec	1
60300	Oil peep hole	1
60301	Regulator knob plug	1
60302	Screw M4x8 Din 933 A2	4
60304	Screw M4x8 Din 912 A4	4
60305	Wedging piece Din 6885-a 5x5x20	1
60312	O-ring 68x1,5 NBR	1
60313	O-ring 44x2 NBR	1
60314	O-ring 17x3,5 NBR	1
60315	O-ring 6,5x2 NBR	1
60318	Washer D8 Din 125 A2	1
60319	Bearing 608-zz (8x22x7)	1
60320	Elastic washer din137-b(21x10.5x1)	5
60333	Screw M4x8 DIN 913 A-2	1
61305	O-ring 88x2,5 NBR	1
61324	Bearing 6206zz (30x62x16) EF	1



62119	Cylinder spacer D40/MF	1
62129	Bellow FPM	1
62300	O-ring 19x3 FPM	2
62352	Screw M6x12 Din 933 A2	4
62451	Bearing 6202 zz	2
62453	Retaining ring 15 Din 471	2
63124	filler plug	1
63125	3/8" drain plug	1
63212	Screw M5x12 Din 912 A2	5
63213	Washer 18x5x2,5 F5	1
64310	O-ring 55,5x3,5 NBR	1
66334	Nut M6 Din 934 A2	1
66344	Washer D6 Din 125 A2	1
67100	Diaphragm D69	1
67104-I	Diaphragm base D69 Inox	1
67104.2-P/F	Diaphragm base D69	1
67105.1-I	Diaphragm cylinder D69 3/4" Inox	1
67105.2-P/F	Diaphragm cylinder D69 3/4"	1
67114	Diaphragm D95	1
67115-P/F/I	Diaphragm cylinder D95	1
67116	Diaphragm base D95	1
67117	Diaphragm flange D95	1
67117-I	Diaphragm flange D95 s.s.	1
67118	Diaphragm D115	1
67119-P/F/I	Diaphragm cylinder D115	1
67121	Diaphragm flange 115	1
67121-I	Diaphragm flange D115 s.s.	1
67123	Diaphragm base 115	1
67300	Screw M8x40 Din 912 A2	4
67301	Screw M8x10 iso 7380 A2	4
67302	Screw M8x60 Din 912 A2	4
70304	Screw M5x20 Din 912 I	4

ASSEMBLIES

27-050	Additional ventilation 24vdc IP56 DOSTEC AC1-2	1
29-057	PCB and base encoder DOSTEC AC	1
29-058	Encoder AC1-2 (dostec40)	1
29060	Advance Control AC1 110Vac	1
29061	Advance Control AC2/3 230Vac	1
60-015	Rod slider D40-D assembly	1
60-021	Regulator p 0,9 mm D40 assembly	1
60-022	Regulator p 1,5 mm D40 assembly	1

VALVES

60-808.1-F/I	Suction check valve hose 6X12 3/4	
60-809.1-F/I	Discharge check valve hose 6X12 3/4	
60-858-P	Suction check valve 6x12 3/4 PP Borosilicate	
60-859-P	Discharge check valve 6X12 3/4 PP Borosilicate	
62-806-F	Suction check valve 3/4 PVDF	
62-807-F	Discharge check valve 3/4 PVDF	
62-856-P	Suction check valve 3/4 PP Borosilicate	
62-857-P	Discharge check valve 3/4 PP Borosilicate	
63-803-I	Suction check valve 3/4 s.s.	
63-804-I	Discharge check valve 3/4 s.s.	
60-814.1-P/F/I	Priming valve 3/4 max. 50 l/h	
60-840-P/F/I	Priming valve 3/4 max. 500 l/h	

MAINTENANCE KIT

60-080-P	Maintenance kit Dostec-40 D69 6X12 PP	
60-081-P	Maintenance kit Dostec-40 D69 3/4 PP	
60-082-P	Maintenance kit Dostec-40 D95 PP	
60-083-P	Maintenance kit Dostec-40 D115 PP	

Materials code: -P= Polypropylene
-F= PVDF
-I= SS 316



VALVES 6X12 (60 l/h max.)

PP / PVDF

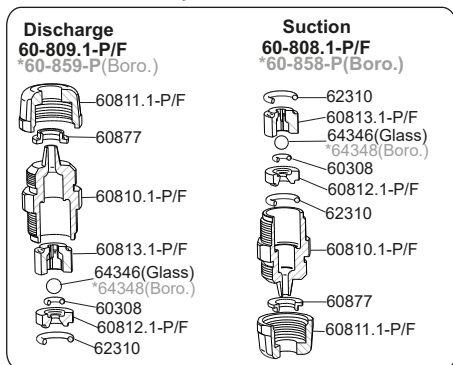

AISI 316

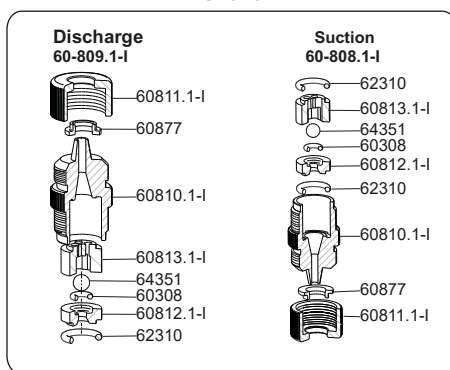

VALVES 3/4 (500 l/h máx.)

PP / PVDF

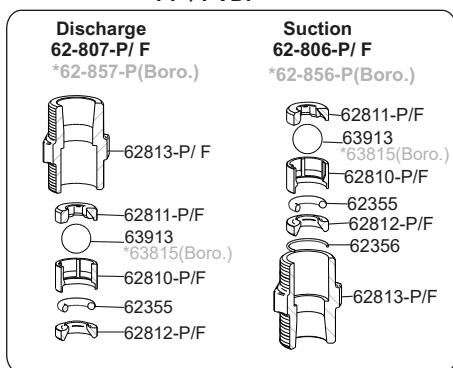

AISI 316

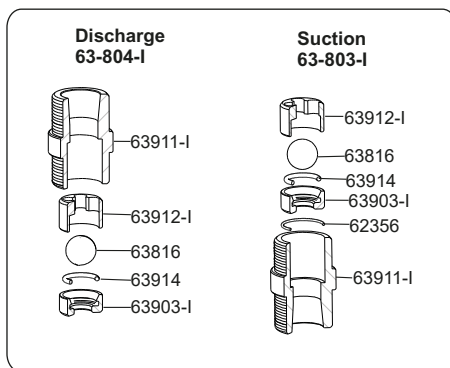

PRIMING VALVES

60-840-P (60l/h máx.)

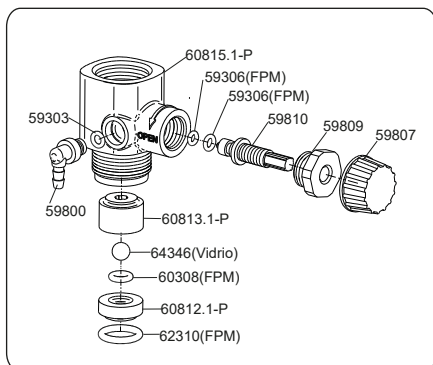

60-814.1-P (500l/h máx.)

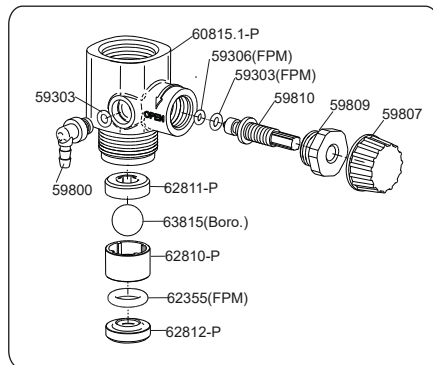

MAINTENANCE



Ensure the following points before any maintenance operation:

The pump is stopped and disconnected from the electric supply.

There is no pressure neither inside the head nor in the discharge pipe. It is advisable to empty the head before opening it.

The staff in charge of the maintenance will use the adequate protection equipment in order to manipulate the dosed liquid.

PERIODICAL MAINTENANCE:

Change the oil after the first 500 hours. Next changes will be every 2000 hours (minimum once a year).

Check the piston every 3 months or 1000 hours.

Check the seals every 3 months or 1000 hours.

Check the diaphragm every 3 months or 1000 hours.

Check the bellows every 3 months or 1000 hours.

Check the suction filter once a month.

Check the valves every 3 months or 1000 hours.

It is advisable to clean periodically the injector, letting clean water flow through it (we can make it coincide with the emptying of the tank), to eliminate precipitated rests that can remain in the inner part of the cylinder or in suction / impulsion pipes.

If we are using highly corrosive liquids it is advisable to double the frequency of checkings.



PROBLEM	CAUSE	SOLUTION
DISPLAY IS OFF	THERE IS NO VOLTAGE MCCB is shut down	- Check with a voltmeter incoming voltage - Check there is no shortcircuit in the power supply
ALARM OF OVERHEATING	PUMP IS WORKING UNDER OVERPRESSURE CONDITIONS DISCHARGE PIPE IS TOO LONG	- Check the pressure in line is lower than the maximum pressure of the unit - Shorter the discharge pipe - Increase the pipe diameter
ALARM OVERVOLTAGE	ADDITIONAL VENTILATION IS STOPPED INPUT VOLTAGE TO HIGH	- Check the wiring of the additional ventilation, and test it connecting it directly to a power supply - Check with a voltmeter incoming voltage
MOTOR RUNS BUT PUMP DOES NOT INJECT OR INJECTION IS INFERIOR THAN NOMINAL ONE	PUMP HAS NOT BEEN PRIMED SUCTION / IMPULSION VALVES ARE DIRTY OR DAMAGED SUCTION FILTER IS DIRTY AIR COMES INTO SUCTION PIPE CAVITATION IN SUCTION	- Prime the pump injecting at zero pressure - Clean or change valves - Clean filter - Check sealing in connection points - Increase suction pipe diameter - Reduce suction pipe length - Reduce speed through an inverter - Use a less viscous liquid
LEAKAGE THROUGH INFERIOR CYLINDER HOLE	DAMAGED DIAPHRAGM DAMAGED PISTON DAMAGE SEALS	- Change diaphragm - Change piston - Change seals
OIL LEAKAGE THROUGH INFERIOR CYLINDER HOLE	DAMAGED BELLOW	- Change bellows



ELECTRICAL WIRING

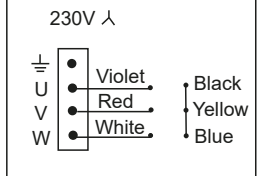
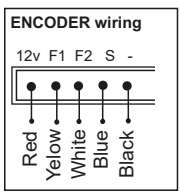
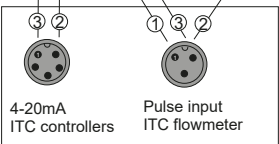
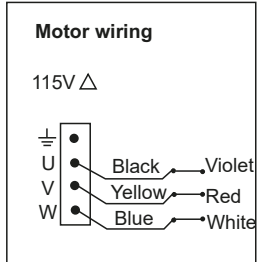
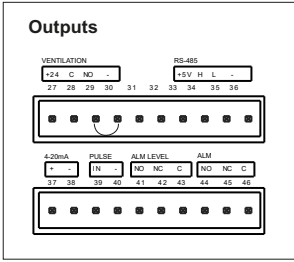
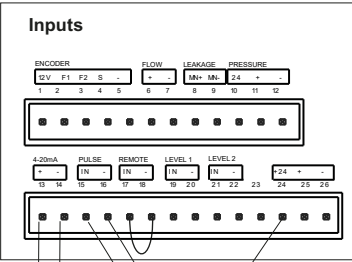
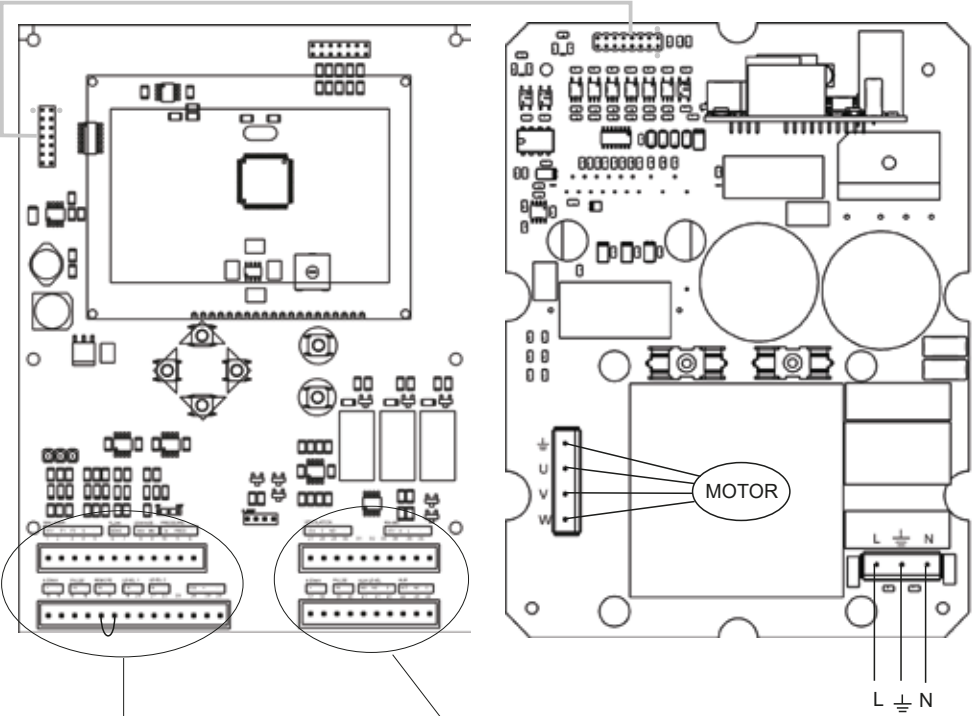

EC CONFORMITY DECLARATION



I.T.C S.L.
Mar Adriàtic, 1
Polígono Torre del Rector
08130 Santa Perpètua de Mogoda

Declares that all models **DOSTEC AC** products, identified by a serial number and year of manufacture, strictly fulfill 2006/042/CE, low voltages directives D2014/35/UE, and electromagnetic compatibility directivess D2014/30/UE, as long as installation, use and maintenance are carried out following the prevailing regulation and following the instructions contained in the handbook.

Antón Planas
Manager

WARRANTY



I.T.C. S.L. Warrants the product specified in this document for a period of 1 year from the purchase date. This warranty obligation is limited to the free replacement of the damaged parts due to any material or manufacture defect. This warranty does not include periodic maintenance and damage resulting from misuse.

The equipment must be sent to **I.T.C. S.L.** Service Center with prepaid transport charges, and will be sent back with transport charges for customer's account.

The warranty document with sales date and shop stamp, or an invoice copy must be sent with the equipment.

MODEL

Sales date and shop stamp

SERIAL #

Original manual

Ed:08/05/2017 AN



C/ Del Mar Adriàtic nº 1 Pol. Ind. Torre del Rector
P.O. Box 60
08130 STA. PERPETUA DE MOGODA
BARCELONA - SPAIN

Tel. 93 544 30 40 Fax 93 544 31 61
e-mail: itc@itc.es www.itc-dosing-pumps.com