

PUMP CONTROL UNIT

Installation & User Guide



Caution ! Installation of the Pump Control Unit should only be performed by a qualified electrician. Injury or death due to electrical shock could occur if the unit is incorrectly installed.

The Pump Control Unit (PCU) is a wireless receiver capable of switching a high current output, typically used to activate a contact breaker circuit to start or stop a pump. It is used with a gulf ICI or RICO transmitter to provide remote control operation of a pump. It can also be used with up to 5 gulf Tank Level Controllers (TLC) to allow remote automatic level control for water tanks or dams.

Pump On/Off Button
Pressing this button starts or stops the pump.

Pump Status Light
Illuminates green when pump is automatically switched on.
Illuminates green and red when pump is manually switched on.
Illuminates red if pump has been manually switched off.

Learn Mode Button
Pressing this button places the PCU in or out of Learn Mode, during which it learns the unique identity of the transmitter unit.

Power Indication Light
Illuminates red when power is on.

High Pressure Indication Light
Illuminates red when a high pressure situation is present.

Learn Mode / Range Test Light
Illuminates red when the PCU is placed into Learn Mode.
Flashes green when a Range Test signal is received.

1. WIRING

1.1 Wiring the Pump Control Unit

You will need to insert a small screwdriver in the upper connector hole to open up the spring loaded connection hole in the lower row. Then insert the wire into the lower hole then remove the screwdriver from the connector in order to clamp the wire in place.

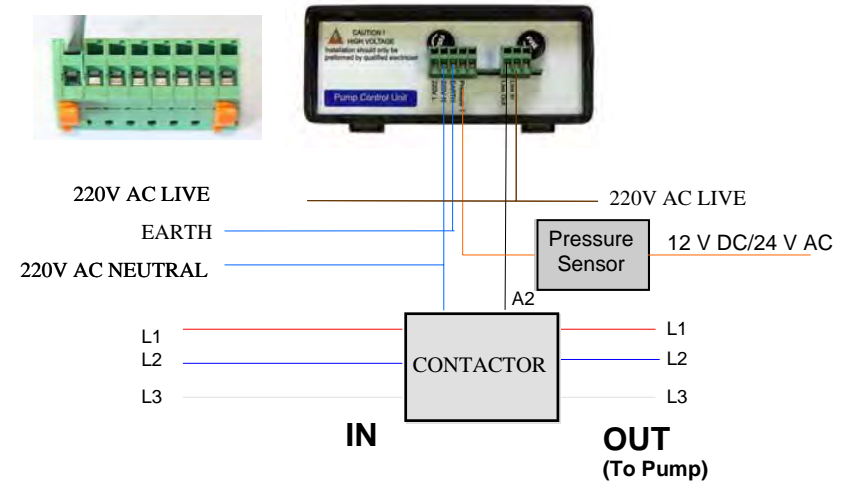

1.2 Connecting the Internal Switch



CAUTION ! Ensure that mains electricity is switched off at the DB board prior to connecting the PCU to any external circuit. Connection to the external circuit should only be performed by a qualified electrician. Injury or death due to electrical shock could occur if the unit is incorrectly installed.

The PCU has an internal high-current switch which is typically used to control an external contact breaker circuit which is used to start and stop a pump.

IMPORTANT ! The specifications shown in the table (right) must not be exceeded.

Parameter	Max Limit
Current	2 Amps
Voltage	380Volts a.c. rms
Frequency	60 Hz

2.0 LEARN PROCEDURE

2.0 Learn Procedure

The PCU firstly needs to learn the unique identity number of the transmitter unit or units that it will work with. This is so that it reacts only to transmitters that it recognises and will not react to somebody else's transmitters.

The Learning procedure is best carried out with the PCU in close proximity to the transmitter unit, although it can be performed with the PCU at its chosen site.

Firstly connect the rubber-duck antenna supplied to the BNC antenna connector. Then the PCU must be connected to the electricity mains in order to operate.

The exact procedure depends on the transmitter type that the PCU is operating with:-

ICI—First place the PCU into Learn mode by pressing the Learn Mode button. The Learn Mode light will illuminate red to indicate that the PCU is in Learn Mode. (If the Learn Mode button is pressed again then the PCU will exit Learn Mode). Then on the ICI press and hold the 'P' button for about 5 seconds. The ICI will then send a Learn transmission to the PCU. The PCU indicates that it has accepted the Learn transmission by switching off the red Learn Mode light and exiting Learn Mode.

RICO — Use the RICO PC software's Configuration Hardware Wizard and follow the steps presented on-screen. You do not need to reconfigure any existing Valve Control Units, simply select the option to set up a Pump Control Unit.

Tank Level Controller (TLC) - First place the PCU into Learn mode by pressing the Learn Mode button. The Learn Mode light will illuminate red to indicate that the PCU is in Learn Mode. (If the Learn Mode button is pressed again then the PCU will exit Learn Mode). Then on the Tank Level Controller press and hold the appropriate Pump button for about 10 seconds e.g. If this Pump Control Unit is controlling Pump Number 1 then press and hold the Pump1 button, if this Pump Control Unit is controlling Pump Number 2 then press and hold the Pump2 button etc. The Tank Level Controller will then send a Learn transmission to the PCU. The PCU indicates that it has accepted the Learn transmission by switching off the red Learn Mode light and exiting Learn Mode.

2.1 Positioning the PCU

The PCU must be placed in a position where it is sheltered from the weather, where mains electricity is available, and within reasonable distance of the contact breaker circuit (or other switching device) that it is to operate. Once a suitable position has been found, a Range Test should be conducted to ensure that the PCU is within signal range of the transmitter unit. The method to start a Range Test depends on the transmitter type that the PCU is operating with :-

ICI / RICO —Simultaneously press the 'A' and 'P' buttons. The ICI/RICO will then start to send Range Test signals. It will automatically stop sending after a period of approximately 20 minutes. To manually stop sending Range Test signals press the 'B' and 'C' buttons simultaneously.

2.1 Positioning the PCU (contd)...

Tank Level Controller —Simultaneously press the 'Pump1' and 'Pump4' buttons. The Tank Level Controller will then start to send Range Test signals. It will automatically stop sending after a period of approximately 40 minutes. To manually stop sending Range Test signals press the 'Pump2' and 'Pump3' buttons simultaneously.

Once a position has been found with acceptable signal strength then the PCU can be mounted using the mounting holes and screws provided, taking special care to avoid drilling where there could be existing electrical wiring.

The PCU will indicate receipt of a Range Test signal by flashing the green Range Test light. A full strength signal will be indicated by the Range Test light flashing green 8 times, with each flash spaced approximately one second apart. There is then a break in the signal for about ten seconds before a further 8 transmissions are sent. This sequence is repeated continuously by the transmitter while it remains in Range Test mode.

Num of flashes	Signal Strength
8	Very Good
7	Average
5	Below Average
2	Poor
1	Very weak
0	No Communication

2.2 Automatic Operation

The PCU enters automatic operation immediately after powering up. While in Automatic operation mode it will scan for incoming radio signals from all transmitters that have previously been learned. If any one of the transmitters sends a "PUMP ON" signal then the PCU will activate the internal switch.

The internal switch is deactivated only when ALL of the transmitters indicate that they no longer require the pump to be switched on. As a safety precaution the PCU will automatically switch off the pump if no signals are received for a period of 9 minutes.

If the pump is switched OFF there is a 30 second delay before the PCU will respond to the next pump ON command.

2.2 Manual Operation

Pressing the Pump On/Off button will toggle the present state of the PCU e.g. If the pump is currently off then pressing the Pump On/Off button will cause the pump to switch on.

Note that there is no timeout on manual operations e.g. If the pump is manually switched on it will remain on permanently until manually switched off. Also, the PCU will ignore any incoming radio signals whilst it is operated manually. This is to prevent incoming signals inadvertently overriding the desired manual operation.

To cancel manual operation simply press the Pump On/Off button again.

Once the PCU is operated manually it will ignore incoming radio signals until the reverse manual operation is performed e.g. If the PCU has been manually switched off, then it must be manually switched on again before the PCU will respond to any incoming radio signals.

2. OPERATING GUIDE

WARRANTY

This warranty is issued by the manufacturers of the Pump Control Unit (PCU), hereinafter referred to as the Company. The Company warrants to the original purchaser that for a period of ONE YEAR from the date of purchase, the equipment is free from defect under normal use, both in workmanship and material, subject to the following conditions.

1. Repair or replacement of any part of this equipment, found by the Company to be defective, shall be at the election of the Company. The costs of such repair shall be borne by the Company in full, provided that the equipment is returned via an authorised distribution agent.
2. This warranty shall become void and cease to operate if any repairs to the equipment are effected by any persons not duly authorised by the Company, or if any substitute parts not approved by the Company are used in the equipment, or if the serial number of the equipment is removed.
3. The Company shall not be responsible for damages resulting from fire, flood, civil disturbances or any Act of God. The Company shall not, in terms of this warranty be responsible nor held liable for any consequential loss or damage of any kind caused by or due to the failure or malfunction of the equipment.
4. The Company shall not be responsible for transportation or other costs than those incurred within the provisions of Point 1 of this warranty.
5. This warranty shall not apply to the equipment if it is purchased or used beyond the borders of the Republic of South Africa, Lesotho, Swaziland, Namibia, Botswana, Mozambique, Angola and Zimbabwe.
6. Where service is requested under warranty and no fault or defect can be found by the Company, all costs incurred will be for the purchaser's account.
7. This document, as well as your invoice will serve as proof of purchase. For the purpose of warranty, it will be essential to produce this document and invoice. Failure to do so will render the purchaser liable for the service costs.